

D15P, D15NP

Einbau-Anleitung • Installation instructions • Instructions de montage
• Navodila za montažo

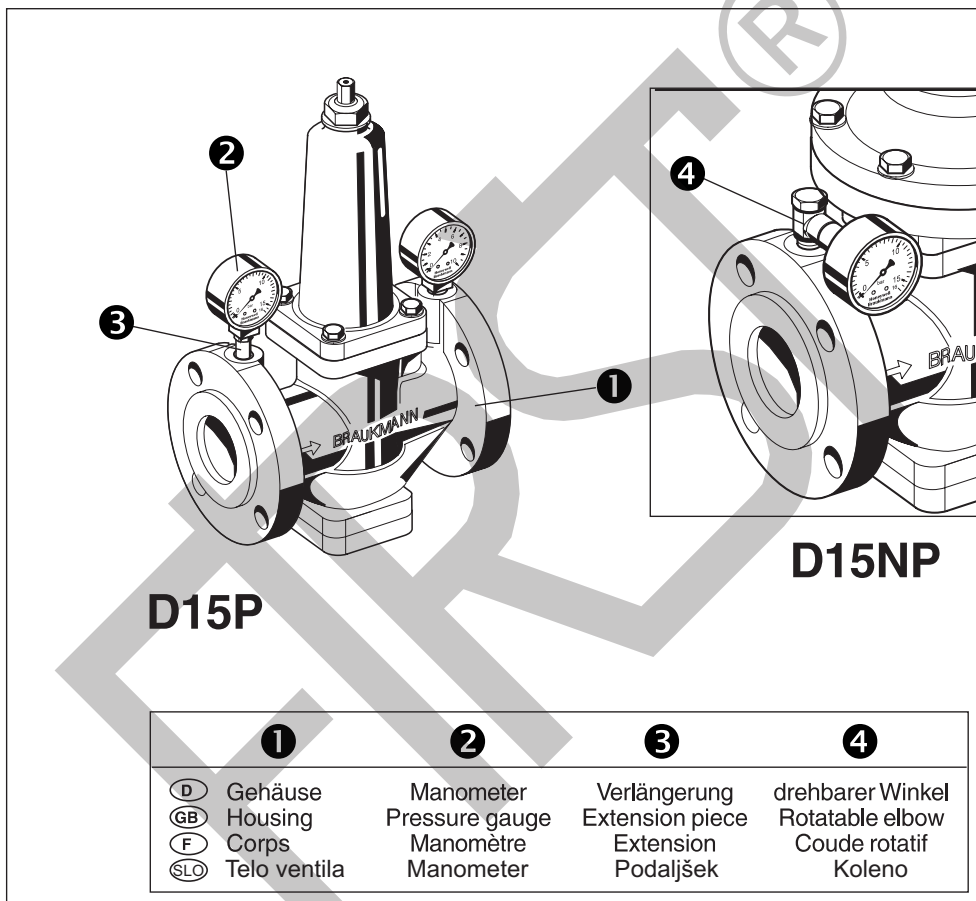

Druckminderer
Pressure Reducing Valve
Régulateur de pression
Regulator tlaka

1. Einbau • Installation • Installation • Instalacija

1.1

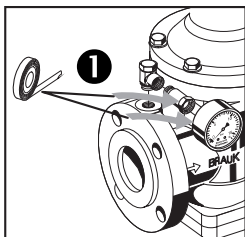

- Rohrleitung gut durchspülen
- Thoroughly flush pipework.
- Bien rincer la tuyauterie.
- Dobro izperite cevi

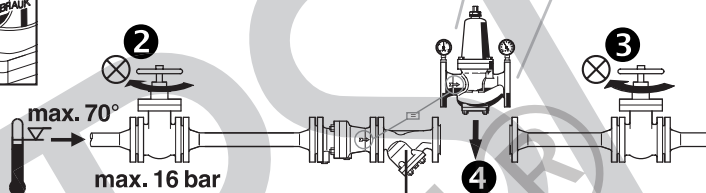

- spannungs-und biegefrei einbauen
- Install without tension or bending stresses
- Eviter des tension et des effets de torsion lors du montage
- Instalirajte ga tako, da ne pride do mehanskih napetosti

- empfohlen
- recommended
- recommandé
- priporočljivo

	D15P		D15NP
	DN50-150	DN200	DN50-200
Hinterdruck Outlet pressure bar pression aval bar Nastavitev izh. tlaka	1,5-8	1,5-6	0,2-2

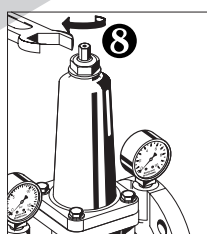
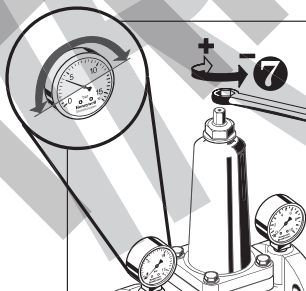
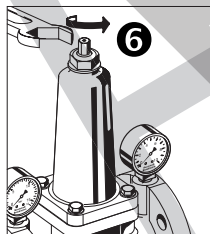
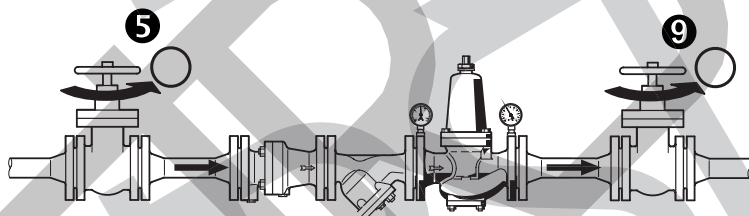

2. Hinterdruck ändern • Changing the outlet pressure • Modifier la pression aval • Sprememba izhodnega tlaka

2.1

- Ausgangsseite druckentlasten (z.B. durch Wasserzapfen)
- Release pressure on outlet side (e.g. through water tap.)
- Détendre le côté d'écoulement (p. ex. par prélèvement d'eau).
- Sprostite tlak na izhodni strani (npr. skozi pipo)

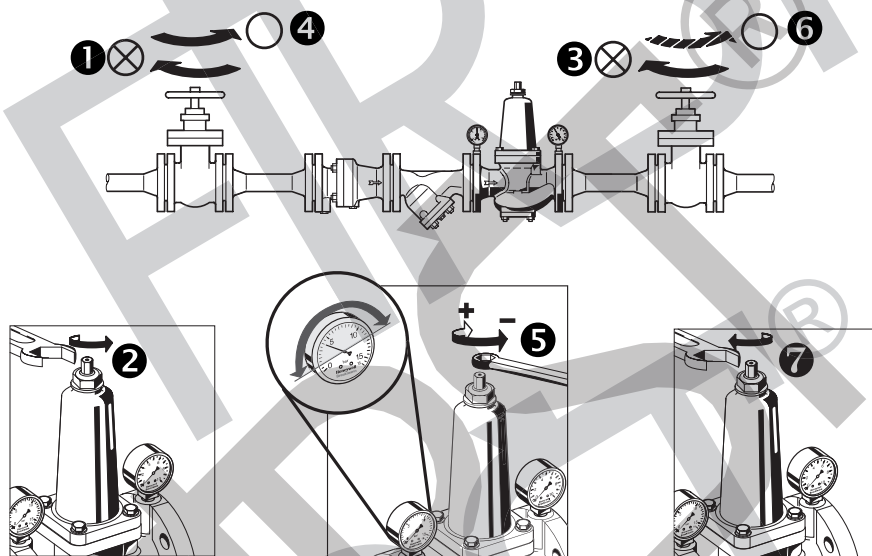

3. Instandhaltung • Inspection and maintenance • Maintenance • Vzdrževanje

3.1

$\dot{V} = 0 \text{ m}^3/\text{h}$ oder
 $\dot{V} = 0 \text{ m}^3/\text{h}$ or
 $\dot{V} = 0 \text{ m}^3/\text{h}$ ou
 $\dot{V} = 0 \text{ m}^3/\text{h}$ ali

$\dot{V} = \text{max}$
 $\dot{V} = \text{max}$
 $\dot{V} = \text{max}$
 $\dot{V} = \text{max}$

P= stabil
P= stable
P= stable
P= stabilni

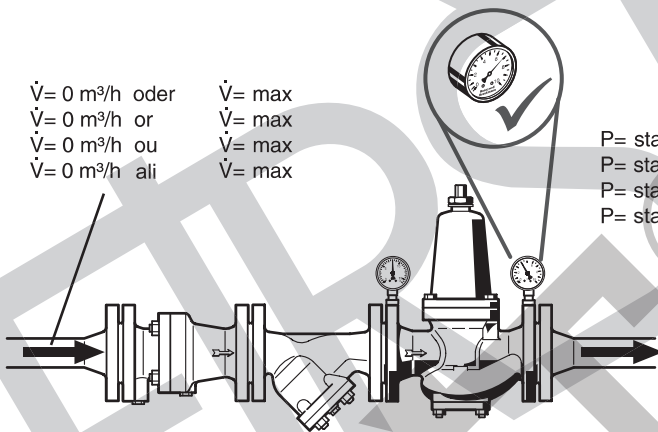

3.2

$\dot{V} = 0 \text{ m}^3/\text{h}$ oder
 $\dot{V} = 0 \text{ m}^3/\text{h}$ or
 $\dot{V} = 0 \text{ m}^3/\text{h}$ ou
 $\dot{V} = 0 \text{ m}^3/\text{h}$ ali

$\dot{V} = \text{max}$
 $\dot{V} = \text{max}$
 $\dot{V} = \text{max}$
 $\dot{V} = \text{max}$

P= NICHT stabil
P= NOT stable
P= PAS stable
P= NEstabilni

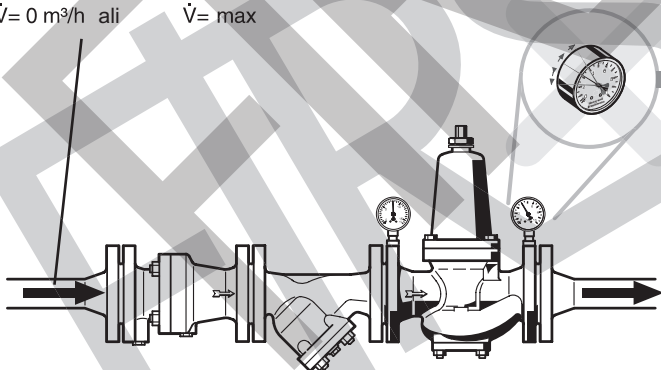

3.3

3.3 DN50-DN150

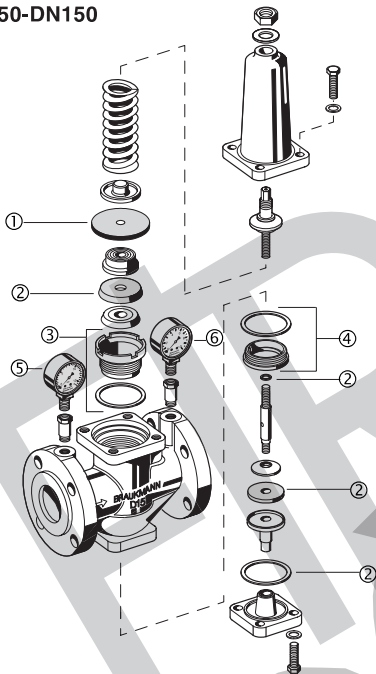

DN200

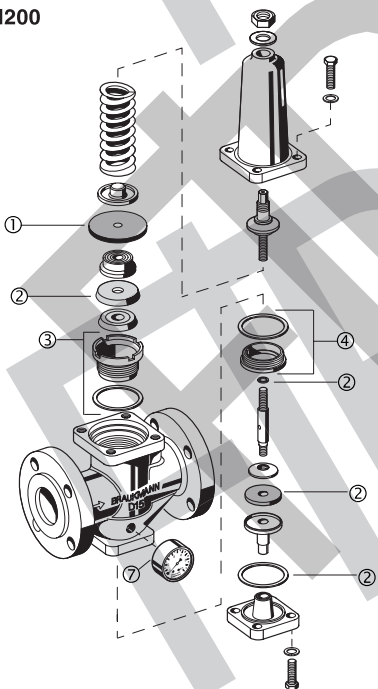

D15P

① DN 50	5707300
DN 65	5707400
DN 80	5707500
DN 100	5707600
DN 125	5707700
DN 150	5707800
DN 200	5707900
② DN 50	0901353
DN 65	0901354
DN 80	0901355
DN 100	0901356
DN 125	0901357
DN 150	0901358
DN 200	0901359
③ DN 50	0900255
DN 65	0900256
DN 80	0900257
DN 100	0900258
DN 125	0900259
DN 150	0900260
DN 200	0900261
④ DN 50	0900247
DN 65	0900248
DN 80	0900249
DN 100	0900250
DN 125	0900251
DN 150	0900252
DN 200	0900253
⑤ DN50-DN150	M39M-A16
⑥ DN50-DN150	M39M-A10
⑦ DN200	M07M-A10

4. Austauschteile • Exchange parts • Pièce de rechange • Servisni deli

3.4

DN50, DN65, DN200

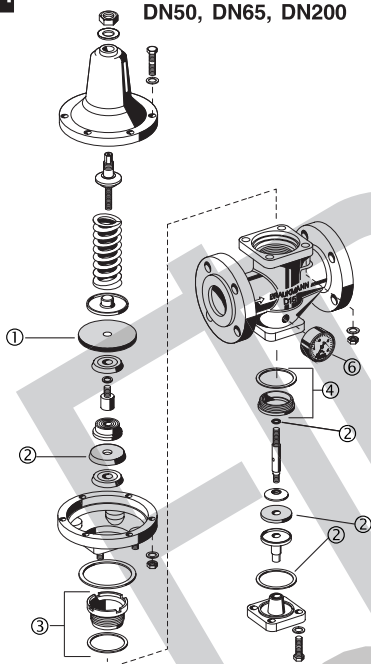

DN80-DN150

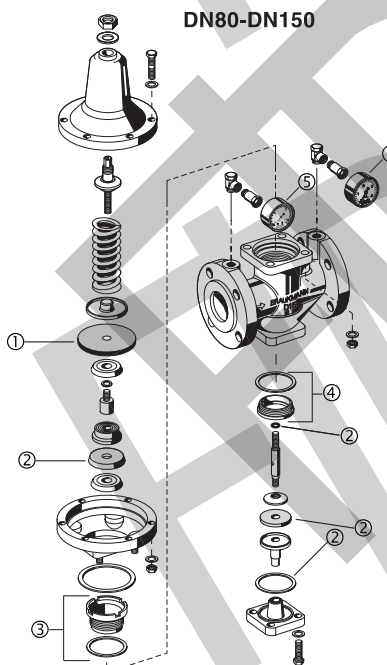

D15NP

①	DN 50	5708000
	DN 65	5708100
	DN 80	5708200
	DN 100	5708300
	DN 125	5708400
	DN 150	5708500
	DN 200	5708600
②	DN 50	0901353
	DN 65	0901354
	DN 80	0901355
	DN 100	0901356
	DN 125	0901357
	DN 150	0901358
	DN 200	0901359
③	DN 50	0900255
	DN 65	0900256
	DN 80	0900257
	DN 100	0900258
	DN 125	0900259
	DN 150	0900260
	DN 200	0900261
④	DN 50	0900247
	DN 65	0900248
	DN 80	0900249
	DN 100	0900250
	DN 125	0900251
	DN 150	0900252
	DN 200	0900253
⑤	DN80-DN150	M07M-A16
⑥	DN50-DN200	M07M-A4

5. Wichtige Hinweise • Important notes • Indications importantes • Pomembna opozorila



(D)

Benutzen Sie das Gerät

- in einwandfreiem Zustand
- bestimmungsgemäß
- sicherheits- und gefahren bewusst.

Einbau-Anleitung beachten.

Störungen sofort beseitigen lassen.

Die Druckminderer D15P/D17P und D15NP sind ausschließlich für die genannten Einsatzgebiete bestimmt. Eine andere oder darüber hinausgehende Benutzung gilt als nicht bestimmungsgemäß.

Alle Montagearbeiten sind durch autorisiertes Fachpersonal auszuführen.



(GB)

Use the appliance

- In good condition
- According to regulations
- With due regard to safety.

Follow installation instructions.

Immediately rectify any malfunctions.

D15P/D17P and D15NP pressure reducing valves are exclusively for use in applications detailed in these installation instructions. Any other use will not comply with requirements.

All assembly operations should be carried out by competent and authorised personnel.



(F)

N'utiliser l'appareil que

- dans un état impeccable
- selon les prescriptions
- en tenant compte de la sécurité.

Observer l'instruction de montage.

Remédier immédiatement à tout défaut.

Les détendeurs D15P/D17P et D15NP sont uniquement destinés au domaine d'application dont il est question dans ces instructions de montage. Tout autre emploi est considéré comme étant contraire à leur but.

Tous les travaux de montage doivent être exécutés par un personnel compétent ayant reçu l'autorisation.



(SLO)

Regulator tlaka uporabljajte

- v dobrih pogojih
- v okvirih zakonodaje
- upoštevajte varnostne predpise.

Upoštevajte navodila za uporabo.

Takoj javite tehničnemu osebju vsako okvaro na napravi.

Regulator tlaka uporabljajte samo v aplikacijah, ki so navedene v teh navodilih. Za ostale aplikacije regulator tlaka ni primeren.

Vse operacije montaže ali popravila lahko izvede samo kompetentna in strokovno usposobljena oseba.

Pridržujemo si pravico do sprememb brez predhodne najave.



6. Zubehör • Accessories • Accessoires • Priporočamo za vgradnjo

RV283P

- (D) Rückflussverhinderer
- (GB) Non return valve
- (F) Clapet antiretour
- (SLO) Protipovratni ventil



FY69P

- (D) Schmutzfänger
- (GB) Y Strainer
- (F) Capteur d'impuretés
- (SLO) Y čistilni filter

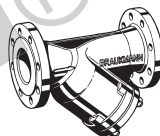

F76S-F

- (D) Feinfilter
- (GB) Reserve-rising filter
- (F) Filtre fin
- (SLO) Samočistilni filter

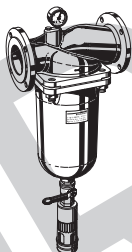

FIRST®

FIRST-ROTOTEHNIKA, s.p.
Radegunda 54, 3330 Mozirje

PE VELENJE:

Koroška c. 56a, 3320 Velenje
tel: 03/ 898 35 00, fax: 03/ 898 35 35
e-mail: info@first.si, <http://www.first.si>

CENTRALNI SERVIS:

Koroška c. 56a, 3320 Velenje
tel: 03/ 898 35 30, 031 608 393, 041 608 393