

BA298-F

Reduced-pressure-zone backflow preventers with flanged connections

Product specification sheet

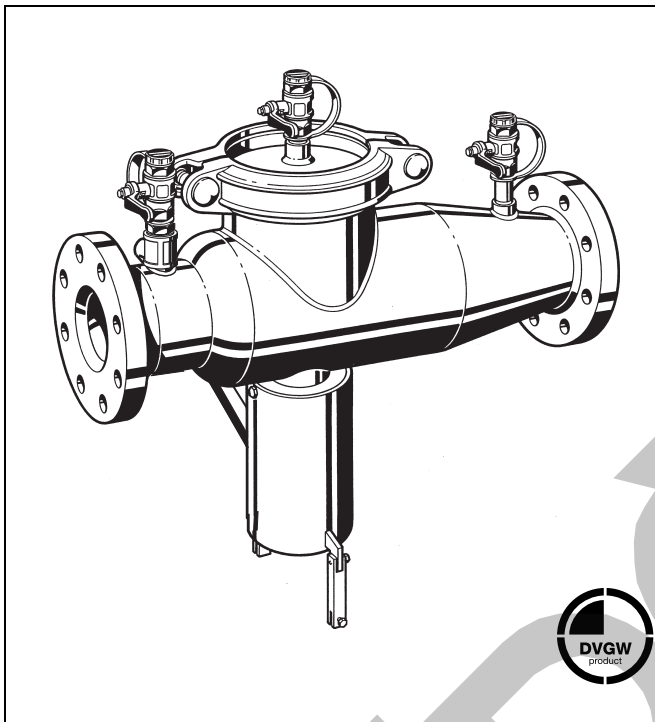

Application

Backflow preventers of this type are suitable for the protection of drinking water systems against back pressure, back flow and back syphonage.

Fluids up to and including liquid category 4 to EN 1717 are protected.

They can be used for residential buildings, industrial and commercial purposes within the scope of their specification.

The stainless steel housing provides increased corrosion protection.

Special Features

- DVGW, WRC and SVGW tested for all connection sizes
- Optimal protection of the drinking water supply system
- Easy access to all internal components
- Stainless steel housing gives increased corrosion protection
- Easy Maintenance due to optimized construction
- Triple security - two check valves and a discharge valve separate the backflow preventer into three pressure zones
- Few individual parts
- Light weight
- Standardised discharge connection
- Meets KTW recommendations for potable water

Range of Application

Medium	Water
Inlet pressure	10.0 bar
Operating pressure	1.5 bar

Technical Data

Installation position	Horizontal with discharge valve downwards
Max. operating temperature	65 °C
Discharge pipe connection	DN150
Connection size	DN65 - DN150

Construction

The backflow preventer consists of:

- Housing
- Inlet and outlet check valves
- Discharge valve
- Three ball valves for the connection of a differential pressure gauge

Materials

- Stainless steel housing
- Niro and brass check valve (DN65-100) resp. red bronze and brass check valve (DN150)
- EPDM diaphragm
- EPDM sealing washers
- Brass discharge valve
- Stainless steel pressure control line
- Nickel plated brass ball valves

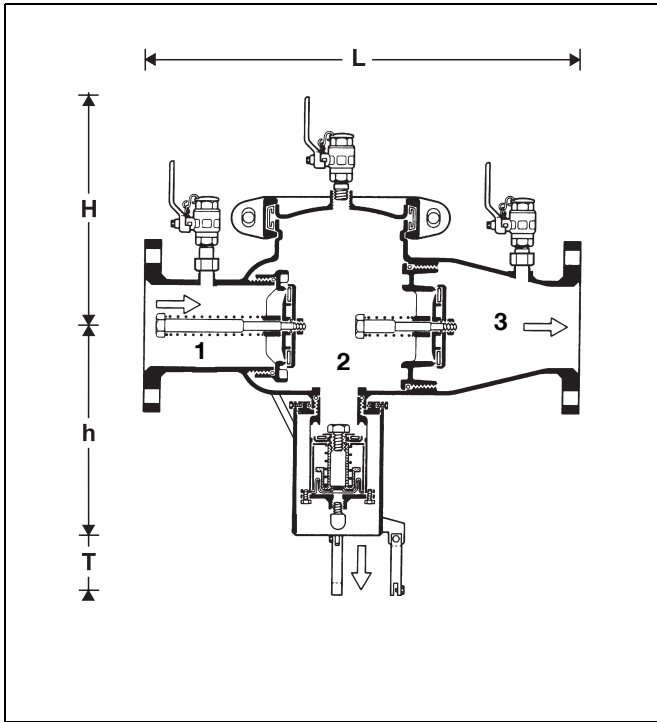

Method of Operation

BA type backflow preventers are divided into three pressure zones. The pressure in zone ① is higher than in zone ②, which in turn is higher than in zone ③. A discharge valve is connected to zone ② which opens at the latest when the differential pressure between zones ① and ② falls to 0.14 bar. The water from zone ② discharges to atmosphere. In this way the danger of back pressure or back syphonage into the supply network is prevented. The pipework connection is interrupted and the drinking water network is protected.

Options

BA298-... FA = Standard version, in sizes DN 65 - 150
flanges in sizes, PN 10

Connection size

Connection size	DN	65	80	100	150
Weight	kg	32	32.5	33	57
Dimensions	mm				
	L	559	559	559	695
	H	245	245	245	285
	h	270	270	270	300
	T	60	60	60	60
Nominal flow rate at $\Delta p = 1$ bar	m ³ /h	45	54	85	191
Discharge flow rates in the event of failure	m ³ /h	35	35	35	35
DIN/DVGW Approval No.		DW - 6305 AU 2008			

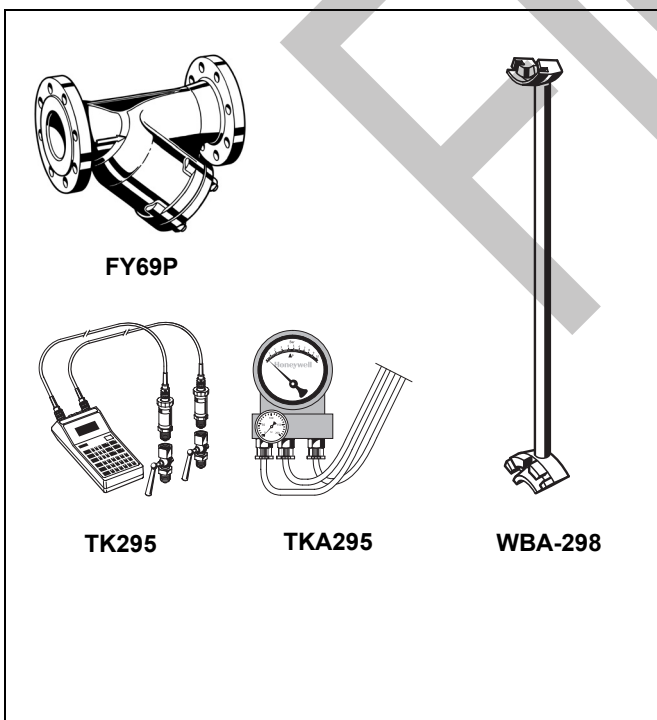

Accessories

FY69P Strainer

With double mesh, grey cast iron housing, powder coated inside and outside.

A = Mesh size approximately 0.5 mm

TK295 Test kit

Electronic pressure measuring device with digital indicator, battery-operated.

With case and accessories, ideal for inspection and maintenance of backflow preventer type BA.

TKA295 Test kit

Analogue pressure measuring device with differential pressure display.

With case and accessories, ideal for inspection and maintenance of backflow preventer type BA.

WBA-298 Check valve replacement tool

WBA-298-100 for connection sizes DN 65 - 100

WBA-298-150 for connection size DN 150

Installation Example

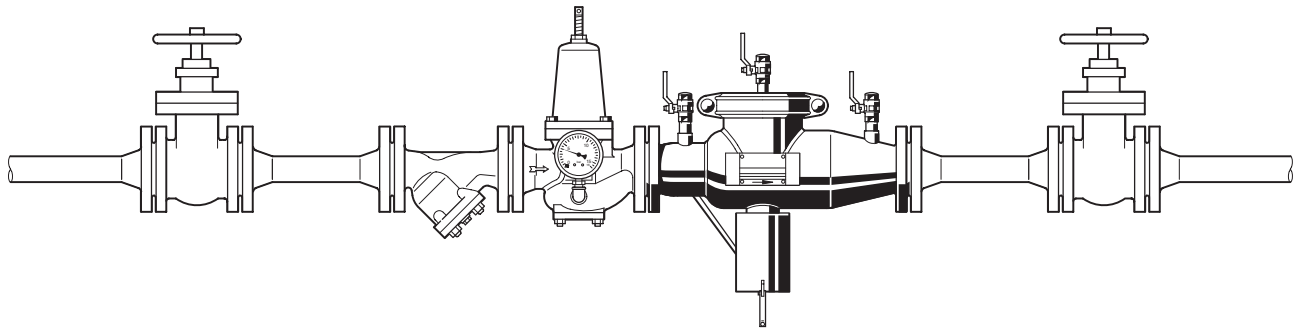

Connection size	DN	65	80	100	150
Minimum clearance above backflow preventer	(mm)	650	650	650	650
Clearance from wall	(mm)	160	160	160	200

Installation Guidelines

- Install shutoff valves before and after backflow preventer
- Install in horizontal pipework with the discharge valve downwards
- Ensure good access
 - o Simplifies maintenance and inspection
- Do not install in places where flooding can occur
- The installation environment should be protected against frost and ventilated well
- Install discharge pipework which has adequate capacity

Typical Applications

Backflow preventers are ideally suited for industrial and commercial applications.

However they can also be used for supplies to residential buildings within the scope of their specification.

The following are some typical applications:

- Chemical mixing plant
- Chemical cleaning appliances
- Softening and deacidification plant without DVGW approval. Regeneration with and without acid and alkaline solutions. Disinfection with Formalin
- Film development plant without DVGW certification
- Galvanic bath

Flow Diagram

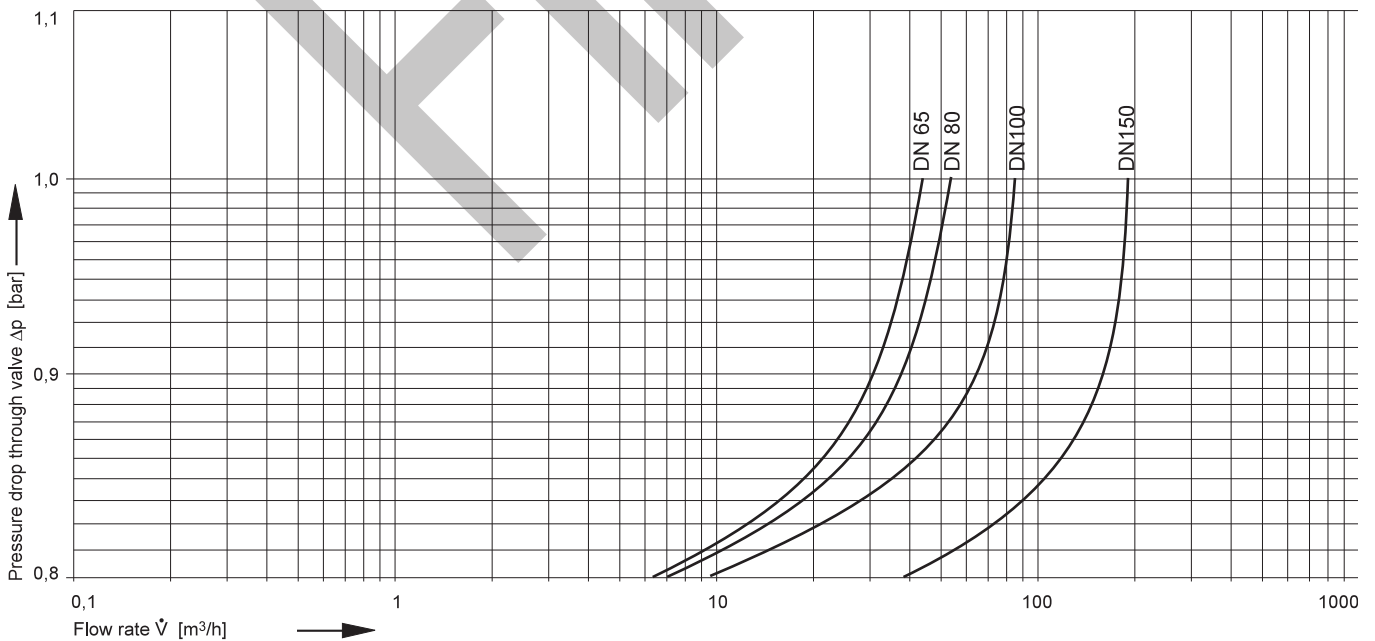

EN0H-1218GEZ3 R0309 • Subject to change

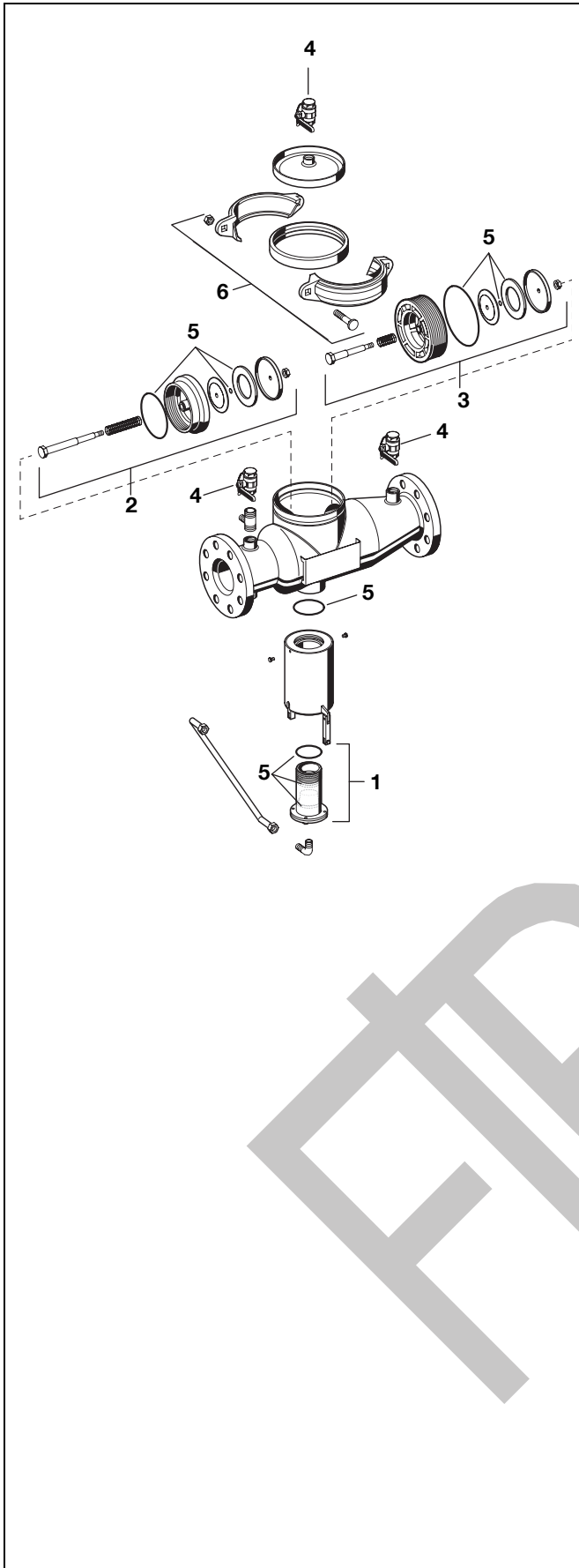

Spare Parts

Backflow Preventer BA298-F, from 2008 onwards

No.	Description	Dimension	Part No.
1	Discharge valve	DN65 -150	0901855
2	Inlet ckeck valve	DN65 -100 DN150	0901650 0901654
3	Outlet check valve	DN65 -100 DN150	0901651 0901655
4	Ball valve	DN65 -150	0901659
5	Sealing set	DN65 -100 DN150	0904031 0904032
6	Clamp complete	DN65 -100 DN150	0904033 0904034

Automation and Control Solutions

Honeywell GmbH
 Hardhofweg
 D-74821 Mosbach
 Phone: (49) 6261 810
 Fax: (49) 6261 81309
<http://europe.hbc.honeywell.com>
www.honeywell.com

Manufactured for and on behalf of the
 Environmental and Combustion Controls Division
 of Honeywell Technologies Sàrl, Rolle, Z.A. La
 Pièce 16, Switzerland by its Authorised Repre-
 sentative Honeywell GmbH

EN0H-1218GE23 R0309
 Subject to change without notice
 © 2009 Honeywell GmbH

Honeywell