

Advantages of motor actuated ball valves of EMV110.. series with incorporated relay module for solar heating systems

In solar heating systems motor actuated ball valves can prevent various inconveniences.

- Effectively prevent hydraulic shocks in systems as they require 30 seconds for complete opening.
- Due to their shape they do not impede the flow.
- Springs are not included, therefore noise does not appear.
- When closed, 100% sealing is guaranteed.
- They have an output for pump up to 1000 W in open position, therefore they do not present a hydraulic load for pump in closed position. They enable pump switching on only in completely open position.
- Due to installed RELAY module they enable control with make contact only.
- If during closing or opening process impurities enter in valve, which could block it, the valve stops and immediately afterwards continues with opening or closing process in opposite direction, so that water flow can rinse the impurities up to cleaning net (anti-blocking system).

EMV 110 603/4230



EMV 110 602/4230



FIRST®

Differential thermostat for solar systems and combined heating sources and regulation of burner or electric heating element

DTC 100/2 TDG

User's manual Installation and maintenance instructions



FIRŠT-ROTOTEHNIKA, s.p.
Radegunda 54, 3330 MOZIRJE

PE VELENJE

Koroška cesta 56a, 3320 VELENJE
tel. 03/ 898 35 00, fax. 03/ 898 35 35
www.first.si, e-mail: info@first.si

DEAR CUSTUMER

Congratulations

You have bought a DTC 100/2TDG differential thermostat, manufactured according to the latest quality and safety standards. It is made according to the state of art and efficiently utilizes solar energy or alternative sources for domestic water heating. We are convinced that the use of our product will satisfy your needs too and help you to save your money.

Thanks for your confidence

FIRŠT Rototehnika

THE SET CONSIST OF:

- Differential thermostat DTC 100/2TDG
- T1 collector sensor with silicone conductor
- T2 hot water tank sensor with PVC conductor
- Clip for sensor fastening with fixing springs
- Instruction for use
- Warranty certificate

In case any of above specified elements are missing or are defective require your dealer to replace it.

Read the instructions carefully in order to be able to make use of all advantages of the product.

! WARNING !

All examples listed in the instructions are merely indicative. The manufacturer accepts no responsibility for incorrect hydraulic connection of machine part of installations should comply with all safety regulations defined by law and the rules.

We reserve the right to modify the instructions and the technical data of the product without prior notice

Technical data

Supply voltage: 230V, 50Hz +/-10%
 Power consumption 4 VA
 Type of thermostat..... P
 Measurement area -40°C do 160°C
 Adjustable temperature range 10°C - 90°C
 Adjustable difference settings..... 2K - 15K
 Hysteresis of difference 1K - 2K
 Number of sensors 2
 Output: 2x relay: 230V ~, 50Hz, 1(1)A, SPST  :
 - pump control
 - burner control
 Input: 2x sensors
 - BSF1- PVC (gray) cable, lenght 1,5m (DHW sensor)
 - KF - Silicon (red) cable, lenght 2m (collector sensor)
 Humidity:..... 5% - 70% (non condensed)
 Storehouse temperature: 0°C-70°C

Trouble-shooting guide

TROUBLE	POSSIBLE FAILURE	REMEDY
Thermostat inoperative	Plug not connected	Connect plug in socket
Water cools down during night	-Selector switch not in AUTO position -One of retaining valves of the system inoperative (enables thermosiphon water circulation)	-Set the switch to AUTO position -Check machine installation We recommend installation of motor actuated ball valve
When pump is active, unplesant noise in installation is heard	Retaining valve makes noise (weak spring)	Replace nonreturn valve with motor actuated ball valve
Irrespective of the temperatures, pump is inoperative	- Selector switch (2) in position »OFF« - "T2max."(1) set too low(under 20°C)	- Set selector switch (2) to AUTO position - Increase T2max
Irrespective of the temp., pump is continuously switched on.	Selector switch (2) in "ON" position	Set the switch to AUTO position
When "T1" key(7) is pressed Er1 appears	T1 sensor is interrupted	Check T1 senzor
When "T1" (7)key is pressed Er2 appears	T1 sensor is short circuited	Check T1 senzor
Er1 is shown on display	T2 sensor is interrupted	Check T2 senzor
Er2 is shown on display	T2 sensor is short circuited	Check T2 senzor
Control light of the pump is on, but the pump is inoperative	Pump bloked or cable of the pump interrupted	Chek the pump and connection to regulator

HOLES FOR EASIER INSTALLATION OF DIFFERENTIAL THERMOSTAT ON WALL

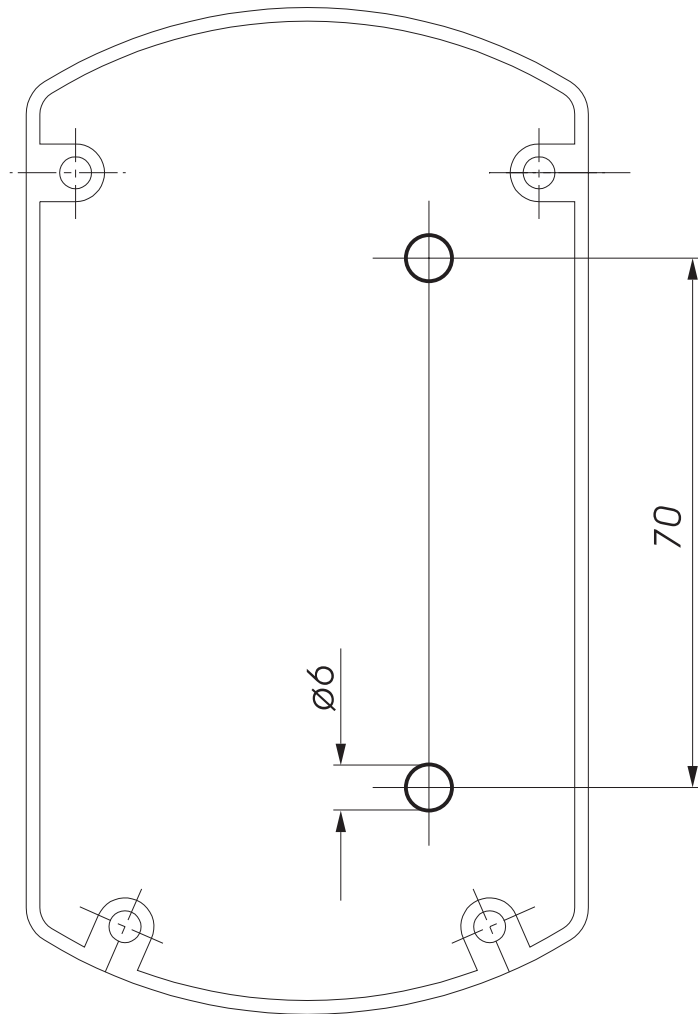

GENERAL

DTC 100/2TDG is a single differential thermostat featuring temperature display, designed for domestic water heating from one heating source (solar collectors, boilers, heat pumps,...) The thermostat controls pump or motor actuated ball valve (EMV 110...) and burner or electric heating element.

Parameter settings:

1. Regulation of maximum temperature in hot water tank from 10° to 90°C.

This temperature is defined by T2 sensor which is generally mounted in upper third of heat exchanger.

2. Regulation of difference for higher exchanger from 2K to 15K

With this parameter you define how much the value of the source temperature (collector, boiler,...) should exceed the temperature of water around the exchanger in hot water tank, that the regulator activates the pump or opens motor actuated valve. The difference is set in relation to the volume of heat losses of the system which depend on lengths of pipelines from source to hot water tank and on pipeline insulation. Built-in digital display enables prompt reading of the temperatures of individual sensors and of all set values as well.

3. It has built in counter of pump working hours.

OPERATION

DTC 100/2TDG single differential thermostat measures the temperature of two heating sources (collectors, boiler ...) and in user (hot water tank).

Heating effect is provided, when heating source temperature is higher than the temperature of the user (water in hot water tank). Consequently minimum adjustable difference is 2° (factory set to 5°). When the temperature of the source (collector) exceeds the temperature around the user for pre-set difference it switches ON the pump and opens motor actuated ball valve.

The thermostat switches OFF the pump if pre-set temperature is reached in hot water tank (adjustable from 10° to 90°C).

If boiler or electric heating element is connected, the thermostat can switch it ON. When is heating required, thermostat switches ON heating source. When the temperature of the source (collector) exceeds the temperature around the user for pre-set difference the thermostat switches ON the pump and opens motor actuated ball valve.

If any sensor is faulty (interrupted or short circuited), thermostat immediately switches off the pump and signalizes the condition on the display ("Er1" - sensor interrupted, "Er2" - sensor short circuited).

INSTALLATION OF THERMOSTAT

Install the thermostat on hot water tank chasing or close to it. Do not install it under the pipe fittings or valves due to possible water dripping on its housing.

SENSOR INSTALLATION

SENSOR INSTALLATION IN COLLECTOR OR BOILER (KF)

⚠ Install sensor with silicon (red) isolation!

Install it as immersion sensor in collecting pipe at the top of the collectors in provided sleeve (picture A).

Connect it on terminals 1 and 2. Recommended type of cable: J-Y (St) 1x2x0,6.

For cables longer than 15m we recommend over-voltage protection with CDR resistor (picture B)

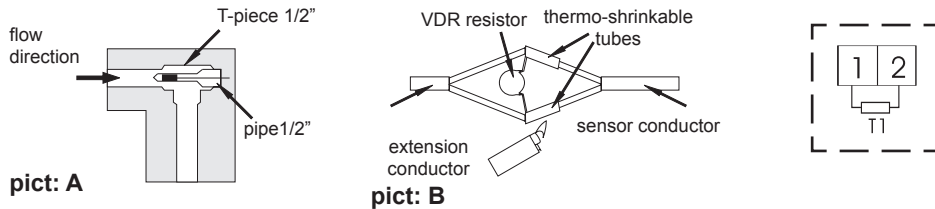

SENSOR INSTALLATION IN HOT WATER TANK.

⚠ Install sensor with PVC (gray) isolation!

Install T2 sensor to provided place in hot water tank or on hot water tank wall under isolation as contact sensor in upper part of exchanger. When sensor is mounted as contact one, we recommend coating it with heat conducting paste or liquid metal.

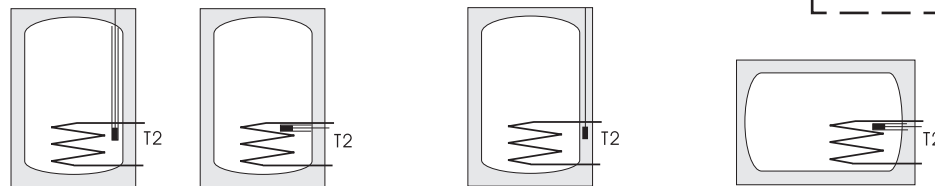

In special purpose vertical or horizontal tube (sensor should be protected against accidental extraction).

On hot water tank with clip, wire and spring strip (use paste for better heat transmission).

In special purpose side tube (protect against extraction).

Warning

By mounting sensors must be assured suitable mechanical protection and sensors must be protected against atmosphere influence.

4. Heating DHWT with oil or gas boiler.

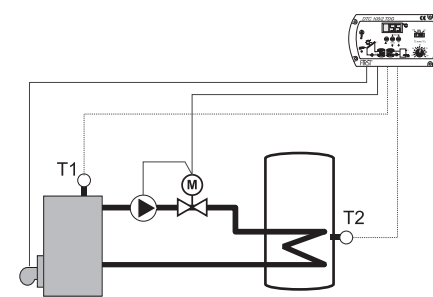

Electrical connection

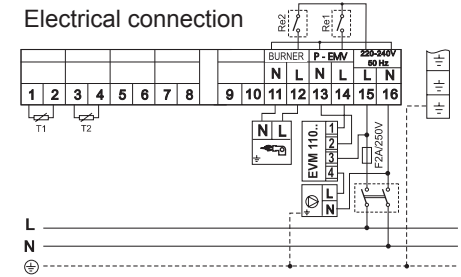

Boiler control:

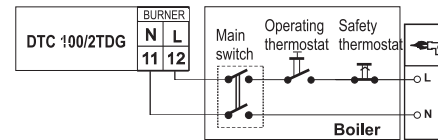

5. Heating DHWT with electrical heater.

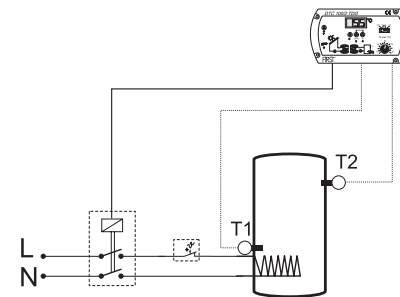

Electrical connection

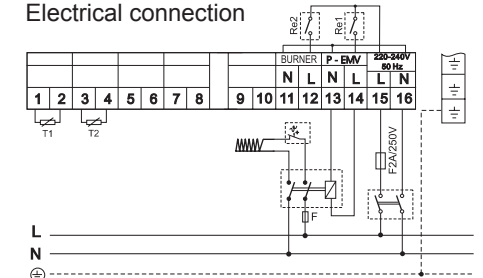

Legend:

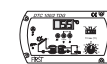

DTC
Differential thermostat
DTC 100/2 TDG



T1, T2
Sensors
T1 - collector sensor
T2 - DHWT sensor



P
Pump



Non return valve



Electric motor actuated ball valve
EMV 110 .. series 602, 603



Electrical heater



Safety thermostat of electric heater



Relay

Examples:

1. Heating DHWT (domestic hot water tank) with solar collectors

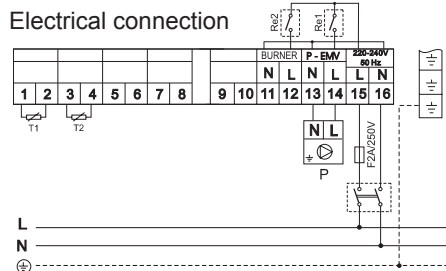
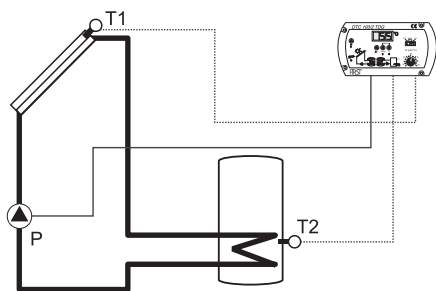

2. Heating DHWT with solar collectors

To prevent thermo circulation of water at night time, we recommend use of motor actuated ball valve. More on last page.

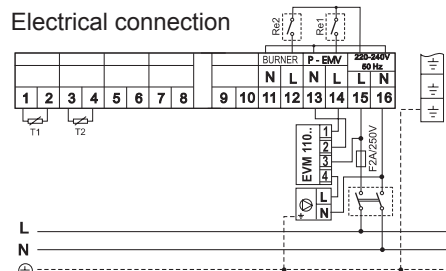
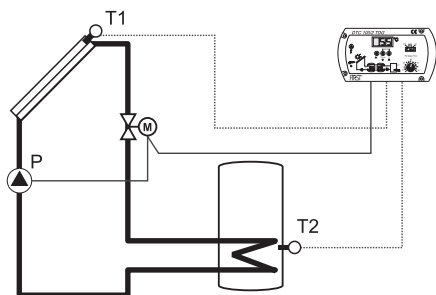

3. Heating DHWT with solid fuel boiler.

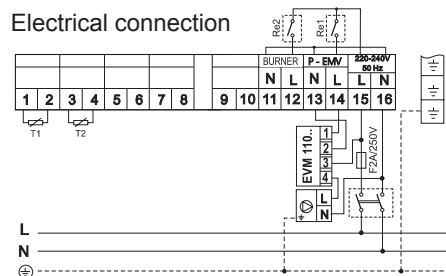
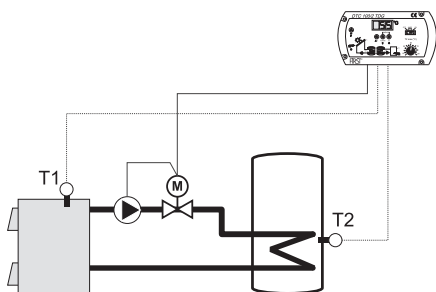

TESTING SENSORS

For testing purposes you can simulate temperatures with resistors.

Temp. (°C)	R _T (Ω)	Temp. (°C)	R _T (Ω)	Temp. (°C)	R _T (Ω)	Temp. (°C)	R _T (Ω)
-50	1040,51	-5	1578,51	40	2229,63	85	2993,87
-45	1094,70	0	1645,27	45	2308,96	90	3085,77
-40	1150,29	5	1713,43	50	2389,69	95	3179,07
-35	1207,27	10	1782,98	55	2471,81	100	3273,76
-30	1265,65	15	1863,93	60	2555,33	105	3369,85
-25	1325,43	20	1926,28	65	2640,24	110	3467,33
-20	1386,61	25	2000,02	70	2726,56	115	3566,21
-15	1449,18	30	2075,16	75	2814,26	120	3666,49
-10	1513,14	35	2151,70	80	2903,37	125	3768,16

Sensor dimensions:

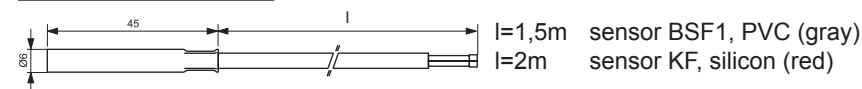

ELECTRICAL CONNECTION

⚠ Before opening unplug power supply! Only qualified person can maintain the thermostat.

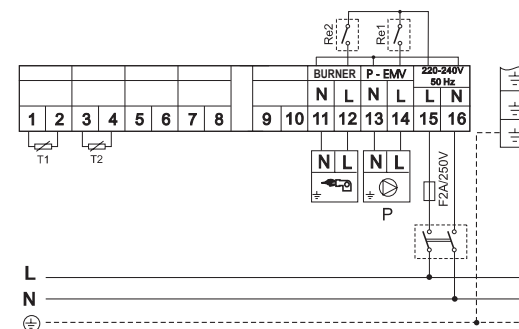

Grounding wires should be connected to special screw terminals situated on right side of terminal strips.

⚠ The thermostat is designed for fixed installation. When performing electric installation, an element should be inserted which enables at least 3 mm separation of thermostat from the mains (switch or socket). Prior to each intervention in the thermostat, first disconnect it from the mains.

Terminal	Connection
1,2	sensor T1 - heating source
3,4	sensor T2 - hot water tank
11	N - neutral conductor
12	L - phase - boiler control 1(1)A, 250V~, 50Hz
13	N - neutral conductor
14	L - phase - pump control 1(1)A, 250V~, 50Hz
15	L - phase - connector for mains 230V~, 50Hz
16	N - neutral conductor for mains

CONTROL PANEL

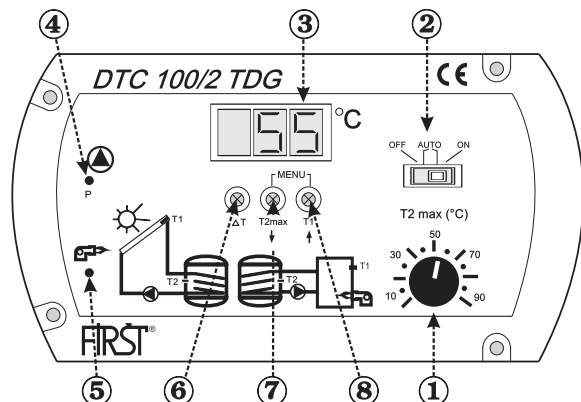

- 1 Regulation of maximum required temperature in hot water tank (10°-90°)
- 2 Operation switch for operation mode selector (OFF, AUTO, ON)
- 3 Display
- 4 Control light for pump operation
- 5 Control light for burner operation
- 6 Key for adjustment of thermostat difference
- 7 Key for max. required temperature display or difference decreasing
- 8 Key for collector temperature display or difference increasing

USE OF SELECTOR SWITCH FOR MANUAL CONTROL

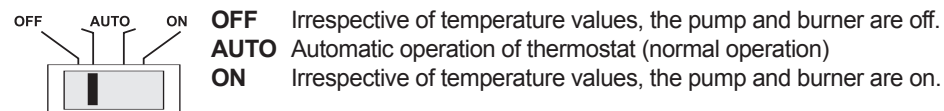

OFF and ON positions are used only for operation tests. OFF position does not enables galvanic separation from mains.

TEMPERATURE DISPLAY:

During normal use display shows "T2" witch is the temperature of water in hot water tank.

If you press "T1" key the display shows the temperature in collectors (T1).

Temperature remains displayed until the key is pressed.

If you press "T2max" key the display shows the maximum temperature set with the knob (1).

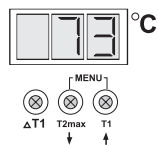

TEMPERATURE SETTING OF HOT WATER TANK

You can set maximum water temperature of hot water tank (from 10° to 90°) with the right key. When the temperature is reached, the thermostat deactivate the pump regardless the temperature of heating source. If hot water is used by the appliance with limited maximum temperature of inflow, this setting is very useful.

NOTE!

Regulator reaction time is 5 sec. max., therefore after each change of knob (1) position you must wait 5 sec. to see the change on the display

DIFFERENCE SETTING:

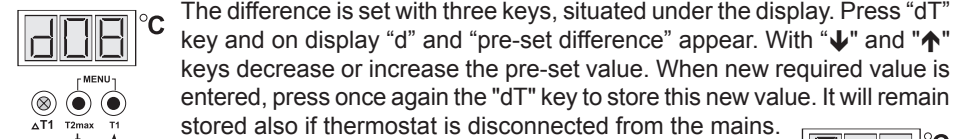

When you set the required difference, press key T1 and hold it!

On the display appears **P.r.** and hold down the key (approximately 3s), until the sign **P.r.** disappear and on display appears the temperature T1. Then release the key.

If you release the key too soon, entered value is not effective.

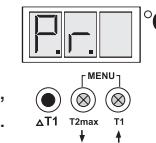

COUNTER OF PUMP WORKING HOURS

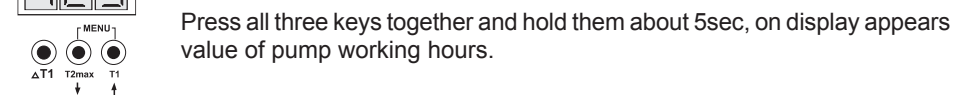

RESETTING COUNTER OF PUMP WORKING HOURS

