



MOTORISED BALL VALVES FOR COOLING SYSTEM



MOTORISCHE KUGELHANEN FÜR KÜHLUNGSYSTEMEN

EMV 110.. series

800HL, 820HL, 830HL, 930HL, 710HL, 910HL -15°..+80°C

FIRST®

INSTALLATION INSTRUCTION AND USER'S MANUAL
MONTAGEANWEISUNG UND BEDIENUNGSANLEITUNG

Installation should be carried out only by a qualified person!
Die Montage darf nur Fachmann ausführen!



DIMENSIONS
ABMESSUNGEN

series 800HL

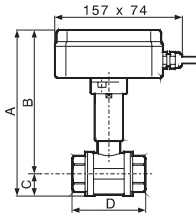

TIP/TYPE	DN	G	A	B	C	D	Kvs	PN		šifra
800/530HL-2	15	1/2"	186	168	17,5	64	17	16	1,09	11412
800/530HL-3	20	3/4"	194	172	22,0	74	41	16	1,24	11413
800/530HL-4	25	1"	202	177	25,5	88	68	16	1,49	11414

TIP/TYPE	DN	G	A	B	C	D	Kvs	PN		šifra
*800/533HL-2	15	1/2"	186	168	17,5	64	17	16	1,10	11422
*800/533HL-3	20	3/4"	194	172	22,0	74	41	16	1,25	11423
*800/533HL-4	25	1"	202	177	25,5	88	68	16	1,50	11424

series 820HL

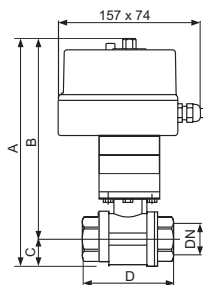

TIP/TYPE	DN	G	A	B	C	D	Kv	PN		šifra
820/410HL-5	32	1 1/4"	269	241	28	101	123	16	2,8	11238
820/410HL-6	40	1 1/2"	285	250	35	105	198	16	3,4	11239
820/410HL-7	50	2"	297	253	44	130	290	16	4,5	11240

TIP/TYPE	DN	G	A	B	C	D	Kv	PN		šifra
*820/413HL-5	32	1 1/4"	269	241	28	101	123	16	2,9	11241
*820/413HL-6	40	1 1/2"	285	250	35	105	198	16	3,5	11242
*820/413HL-7	50	2"	297	253	44	130	290	16	4,6	11243

series 830HL

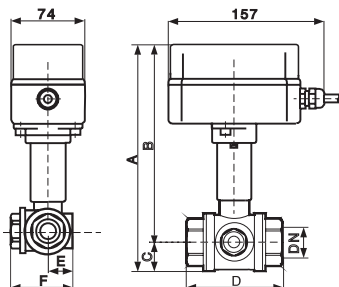

TIP/TYPE	DN	G	A	B	C	D	E	F	Kv	PN		šifra
830/590HL-3	20	3/4"	202	178	24	80	30	73	5,2	16	1,8	11513
830/590HL-4	25	1"	210	183	27	114	57	88	9,2	16	2,5	11514

TIP/TYPE	DN	G	A	B	C	D	E	F	Kv	PN		šifra
*830/593HL-3	20	3/4"	202	178	24	80	30	73	5,2	16	1,81	11523
*830/593HL-4	25	1"	210	183	27	114	57	88	9,2	16	2,51	11524

series 930HL

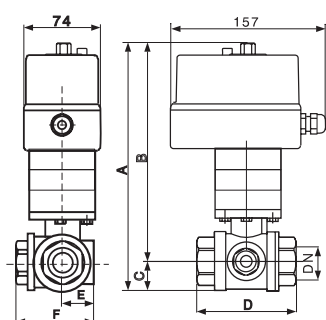

TIP/TYPE	DN	G	A	B	C	D	E	F	Kv	PN		šifra
930/410HL-5	32	1 1/4"	278	245	33	130	64	100	20	16	4,4	11325
930/410HL-6	40	1 1/2"	287	248	39	150	70	115	37,2	16	5,4	11326
930/410HL-7	50	2"	304	257	47	170	90	135	48,7	16	7,4	11327

TIP/TYPE	DN	G	A	B	C	D	E	F	Kv	PN		šifra
*930/413HL-5	32	1 1/4"	278	245	33	130	64	100	20	16	4,4	11525
*930/413HL-6	40	1 1/2"	287	248	39	150	70	115	37,2	16	5,4	11526
*930/413HL-7	50	2"	304	257	47	170	90	135	48,7	16	7,4	11527

series 710HL

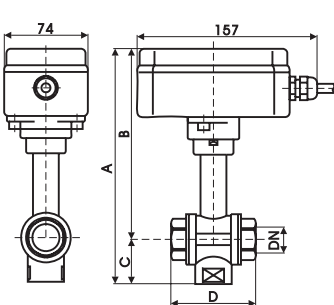

TIP/TYPE	DN	G	A	B	C	D	Kv	PN		šifra
710/550HL-2	15	1/2"	200	160	39	74	3,81	16	1,00	11312
710/550HL-3	20	3/4"	200	160	39	74	7,68	16	1,30	11313
710/550HL-4	25	1"	210	164	46	88	11,6	16	1,60	11314

series 910HL

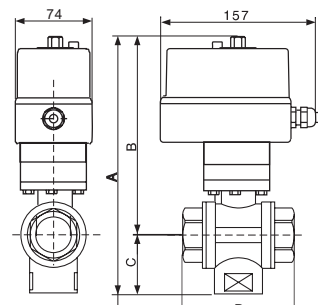

TIP/TYPE	DN	G	A	B	C	D	Kv	PN		šifra
*910/4G0HL-5	32	1 1/4"	254	199	54,5	100	20,7	10	2,5	
*910/4G0HL-6	40	1 1/2"	272	211	61,3	110	47,3	10	3,1	
*910/4G0HL-7	50	2"	290	217	72,8	130	54	6	3,9	

* by special request

	SERIE EMV 110..	800HL	820HL	830HL	930HL	710HL	910HL
Power supply/Elekt. anschluss		230VAC, 50/60Hz	230VAC, 50/60Hz	230VAC, 50/60Hz	230VAC, 50/60Hz	230VAC, 50/60Hz	230VAC, 50/60Hz
Operating / Stellung		Auto / Manual	Auto / Manual	Auto / Manual	Auto / Manual	Auto / Manual	Auto / Manual
Flow indicator		On valve's support <i>An Ventil Trager</i>	On the cover <i>An Deckel</i>	On valve's support <i>An Ventil Trager</i>	On the cover <i>An Deckel</i>	On valve's support <i>An Ventil Trager</i>	On the cover <i>An Deckel</i>
Ambient temperature / Umgebungstemperatur		0°C - 55°C	0°C - 55°C	0°C - 55°C	0°C - 55°C	0°C - 55°C	0°C - 55°C
El. signal (open) - L Elek. Signal (geöffnet) -L		200VA, 50Hz	200VA, 50Hz	200VA, 50Hz	200VA, 50Hz	200VA, 50Hz	200VA, 50Hz
Relay modul / Relais modul		possibility <i>möglichkeit</i>	possibility <i>möglichkeit</i>	possibility <i>möglichkeit</i>	possibility <i>möglichkeit</i>	possibility <i>möglichkeit</i>	possibility <i>möglichkeit</i>
Micro-switch rating / Endschalter		5(1)A, 250VAC	5(1)A, 250VAC	5(1)A, 250VAC	5(1)A, 250VAC	5(1)A, 250VAC	5(1)A, 250VAC
Control / Kontrolle		2-point	3- point	3- point	3- point	2- point	3- point
Power consumption / Leistungsaufnahme		3.5W	5W	3.5W	5W	3.5W	5W
Actuator protection class / Antriebsschutz		IP 55	IP 54	IP 55	IP 54	IP 55	IP 54
Max. operating torque / Max Ausgangsmoment		6Nm	25 Nm	6Nm	25 Nm	6Nm	25 Nm
Rotation time / Rotationszeit		30s/90°	105s/90°	25s/90° * 50s/180° (tip 830HL/570)	105s/90°	60s/180°	210s/180°
Ventil		2 way ball valve	2 way ball valve	3 way ball valve	3 way ball valve	3 way ball valve	3 way ball valve
Connection type / Anschlussart		Internal thread connectors / innengewinde	Internal thread connectors / innengewinde	Internal thread connectors / innengewinde	Internal thread connectors / innengewinde	Internal thread connectors / innengewinde	Internal thread connectors / innengewinde
Coefficient of the conductivity of coupling ¹⁾		F=0,064	F=0,225	F=0,064	F=0,225	F=0,064	F=0,225

ELECTRICAL CONNECTION/ ELEKTRISCHER ANSCHLUSS

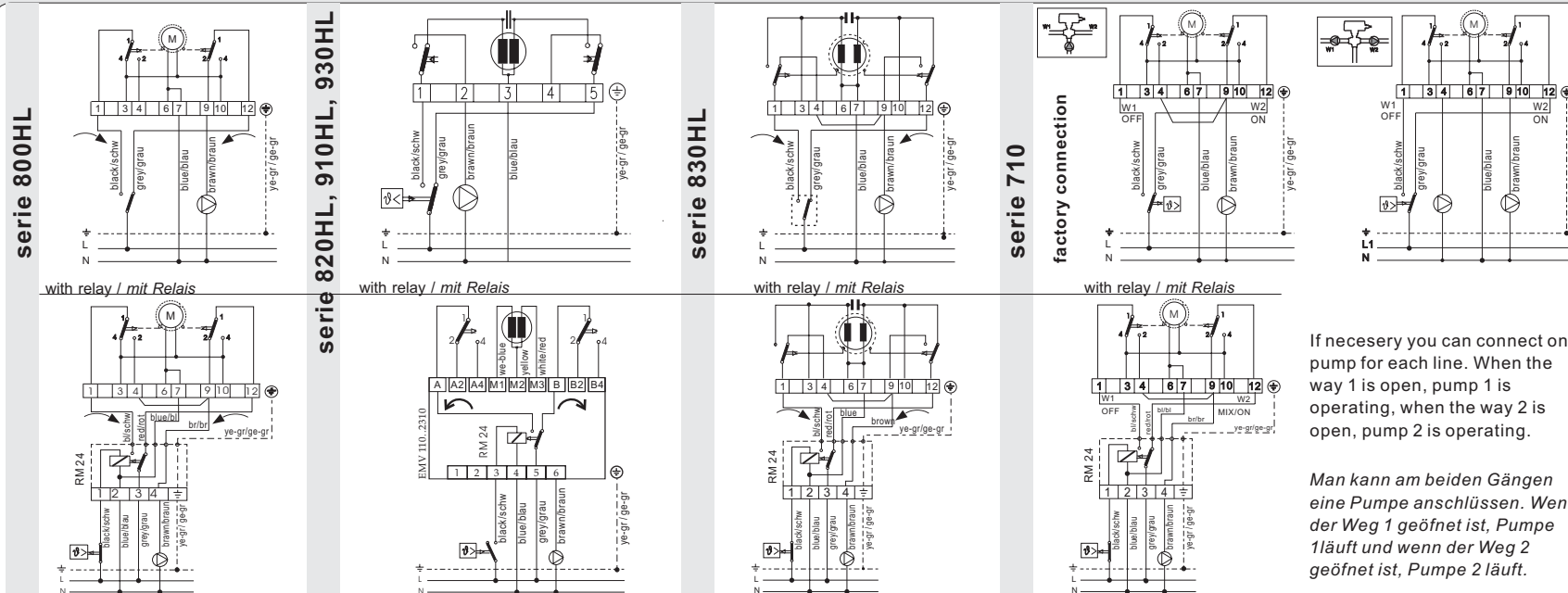

Valve's body: brass, nickel plated
Gehäuse: Messing, Vernickelt
Ball: brass, nickel plated
Kugel: Messing hartverchromt
O-ring gaskets: VITON 3x, PTFE
O-ring Dichtung: VITON 3x, PTFE
Medium: water, non-aggressive media, glycol...
Betriebsbedingungen: Wasser, nicht aggressive Fluide
Fluid temperature: -15°C..+80°C²⁾
Temperature des Fluid: -15°C..+80°C²⁾
Max. pressure: 16 bar

If necessary you can connect one pump for each line. When the way 1 is open, pump 1 is operating, when the way 2 is open, pump 2 is operating.

Man kann am beiden Gängen eine Pumpe anschließen. Wenn der Weg 1 geöffnet ist, Pumpe 1 läuft und wenn der Weg 2 geöffnet ist, Pumpe 2 läuft.

1) Temperature measurements are made on University of Ljubljana, faculty of mechanical engineering, laboratory for cooling technique.
2) The pipes and valves should be insulated.

FLOW DIAGRAM / DURCHFLUSS RICHTUNGEN

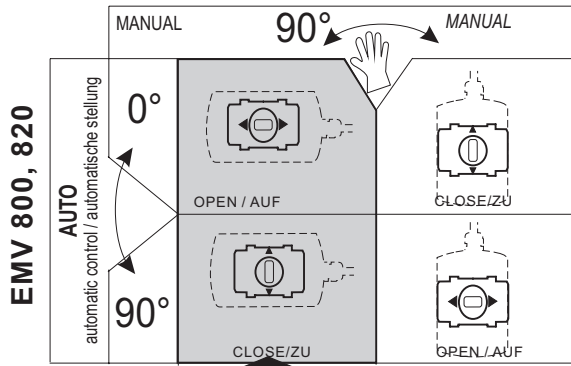

FACTORY SETTINGS/ FABRIK ANSTELLUNG

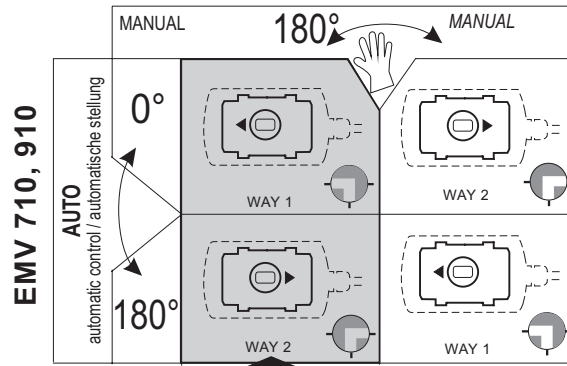

FACTORY SETTINGS/ FABRIK ANSTELLUNG

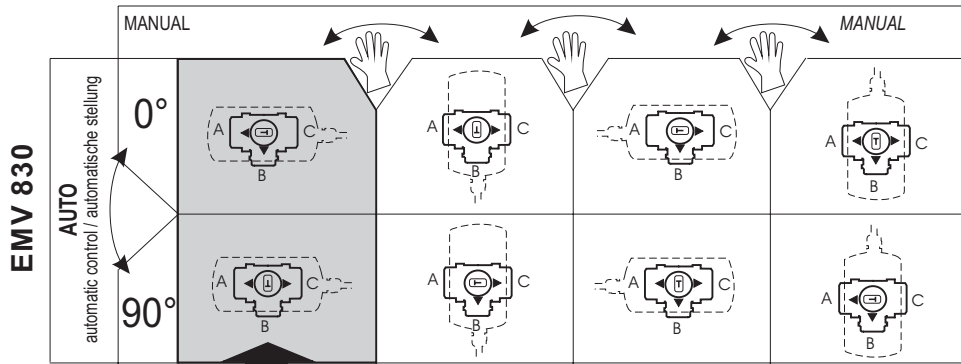

FACTORY SETTINGS/ FABRIK ANSTELLUNG

* By special request EMV 110 830/570

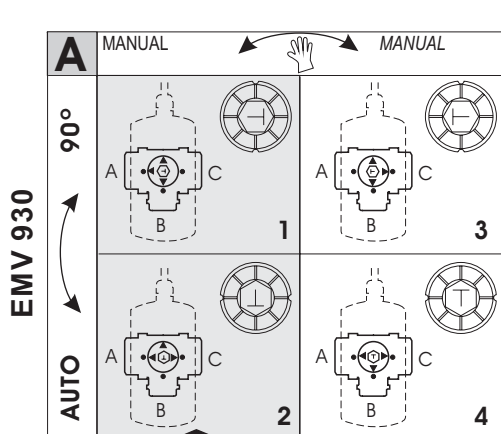
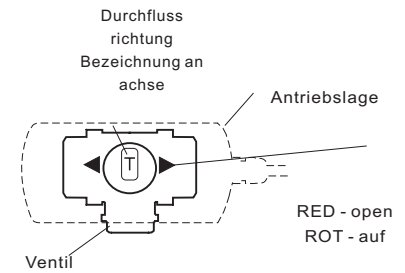
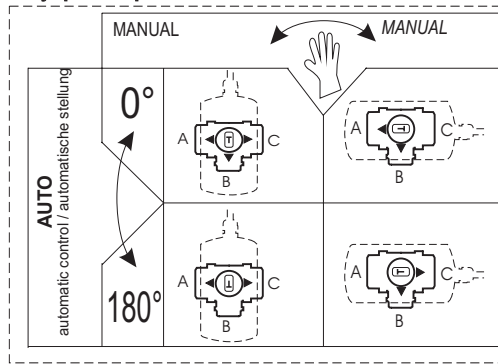

FACTORY SETTINGS/ FABRIK ANSTELLUNG

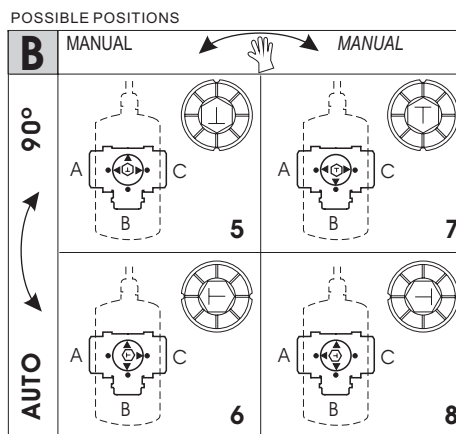

* By special request EMV 110 830/570

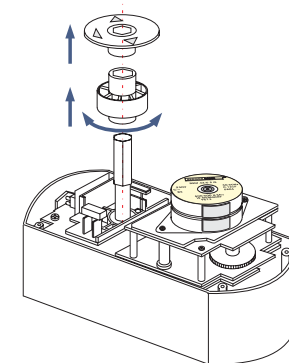
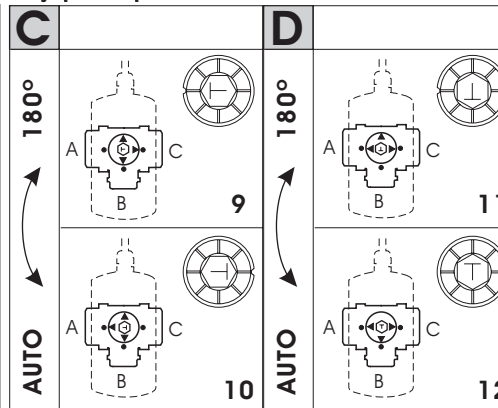

MANUAL OPERATION / HANDSTEUERUNG

serie 800, 830, 710

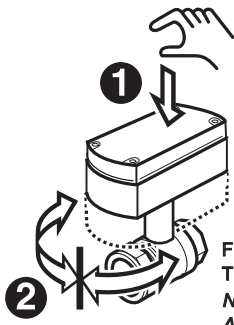

1. depress the actuator towards the valve
Den Antrieb nach Ventil drücken
2. rotate the actuator
Den Antrieb drehen
3. the spring returns and snaps the actuator
Die Druckfeder bringt den Antrieb wieder zurück und schnappt in die eingestellte Lage

FOR AUTOMATIC MOTOR OPERATION, RETURN THE ACTUATOR INTO IT'S ORIGINAL POSITION!
NACH HANDSTEUERUNG BRINGEN SIE DEN ANTRIEB IN DIE ANFANGSLAGE ZURÜCK!

POSITION VALVE INDICATOR ZEIGER DER VENTILLAGE

INDIKATOR / ANZEIGE

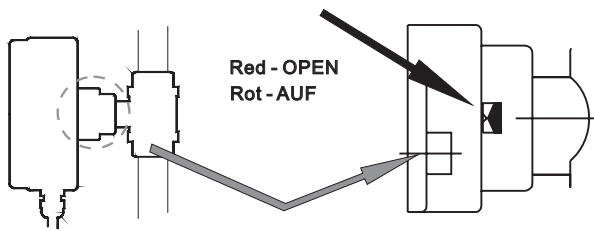

MANUAL OPERATION

series EMV 110 820, 930, 910



With a key 13 move slightly the valve in clockwise or contra clockwise direction in order to release the gears
Schlüssel Nr. 13 auf Achse stecken



Press and rotate the button
Knopf drücken

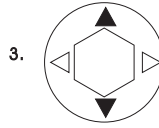

Rotate the valve with the key in desired position:
- red : OPEN / blue : CLOSE
*Schlüssel in gewünschte Richtung drehen
rot = AUF / blau = ZU*



Depress and rotate the button back to the original position
Knopf loslassen

IMPORTANT ! / WICHTIG!

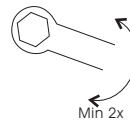

AFTER LONG STANDSTILL PERIOD
Manually rotate the valve with a key for at least two full rotations to release the valve and to clean away impurities from the ball

NACH LÄNGEREM STILLSTAND
Das Ventil manuell mindestens zweimal um den Vollöffnungswinkel drehen, um die Verschmutzung von Ventilkugel zu entfernen und den Antrieb zu entlasten.

BUILD-IN ROOM / EINBAURAUM

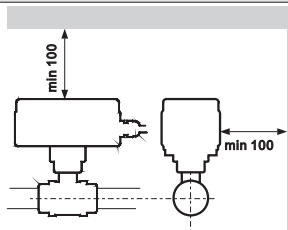

PRIORITY / FÖRRLAGE

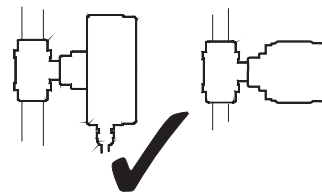

ALLOWED / MÖGLICHE LAGE

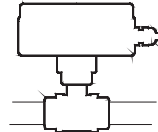

NOT ALLOWED ! UNERLAUBTE LAGE !

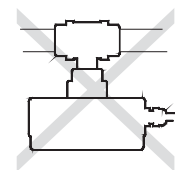

HYDRAULIC INSTALLATION: recommended installation of the electric actuated ball valve SCHEMA DER MASCHINENINSTALLATION: Empfohlener einbau des kugelventils mit elektromotorantrieb

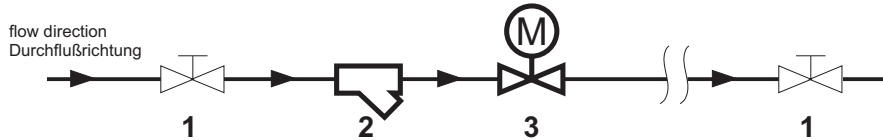

- 1 manual stop valve /
manuelles Absperrventil
- 2 strainer with the mesh width 0,65 mm /
Reinigungsfilter Y (für detaillierte
Informationen bitte rufen Sie uns an
lieferbar in Abmessungen von 1¼" bis 2"
- 3 motor actuated ball valve series
EMV 110...
Elektromotorantrieb mit Kugelventil
EMV 110...

IMPORTANT !

To extend the long term performance of the motorised ball valve it is recommended that a strainer is situated prior to the valve. By installation must be observed to according to relevant local standards.

WICHTIG!

Um die Lebensdauer des Ventil zu verlängern und Vernichtung der Dichtungen durch mechanische Teile in der Installation zu verhindern wird der Einbau eines Reinigungsfilters empfohlen. Die einschlägigen VDE+TÜV - Verschriftensindzubeschten.

RELAY MODULE BUID-IN INSTRUCTION (ONLY for 230V, 50Hz) / RELAIS-EINBAUEN (NUR FÜR 230V, 50Hz)

RELAY MODULE RM 24 RELAIS MODUL RM 24

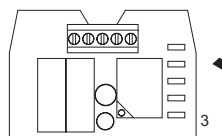

Code Nr.
Art. Nr: 10024

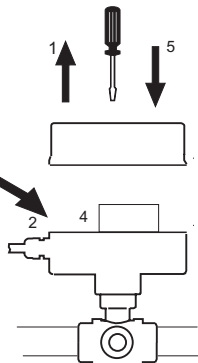

1. Unscrew cover screws
*Die Schrauben des Antriebdeckel
herausdrehen*
2. Disconnect connection cord
Anschlusskabel abklemmen
3. Insert a relay module
Relais Modul einsetzen
4. Connect a relay module according to
scheme
Relais Modul anschliessen
5. Return the cover
Antriebdeckel anschrauben

ELECTRICAL CONNECTION / ELEKTRISCHE ANSCHLUSS

