

GB ELECTRIC MOTOR ACTUATED BALL VALVE
D KUGELHAHN MIT ELEKTROMOTORISCHEM ANTRIEB
 EMV 110..
 SERIES 820



FIRST®

INSTALLATION INSTRUCTION AND USER'S MANUAL
MONTAGEANWEISUNG UND BEDIENUNGSANLEITUNG

Installation should be carried out only by a qualified person !
 Die Montage darf nur Fachmann ausführen !

DIMENSIONS AND ELECTRICAL CONNECTION
ABMESSUNGEN UND ELEKTRISCHER ANSCHLUSS

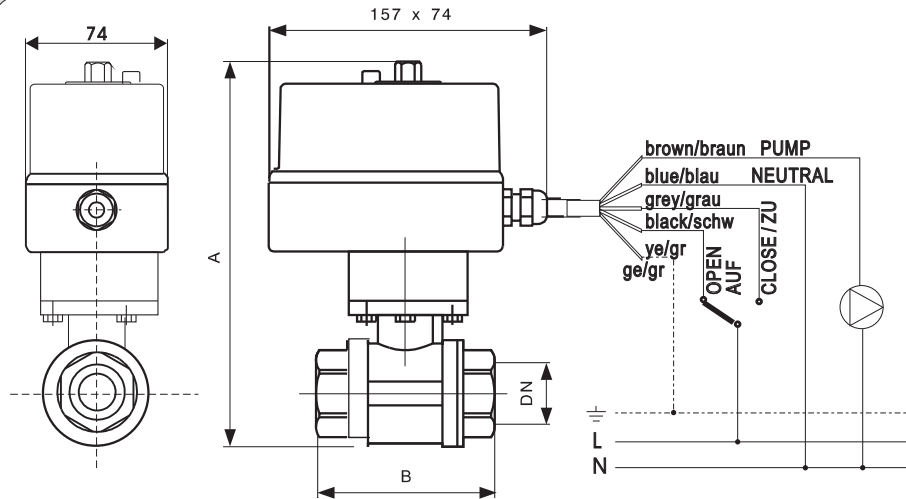

DN	A	B	Kv	kg
32- 1 1/4"	220	102	123	2,40
40 - 1 1/2"	230	106	198	3,00
50 - 2"	242	129	290	4,10

BUILD-IN ROOM
EINBAURAUM

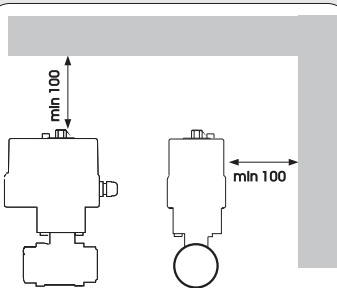

BUILD-IN POSITION
EINBAULAGE

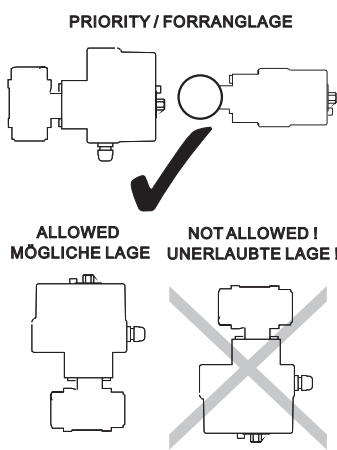

CONDITIONS FOR USE
BETRIEBSBEDINGUNGEN

Fluids and gasses (water, nonaggressive media) up to 16 bar.
 Flüssige und gasförmige Fluide (Wasser, nicht aggressive Fluide) bis zu 16 bar.

TECHNICAL DATA
TECHNISCHE DATEN

Main connection.....Nennspannung230VAC, 50Hz (EMV110..410)
*24VAC, 50Hz (EMV110..413)
 Power consumption.....Nennleistung5 W max
 Rotation time.....Rotationszeit.....105s / 90°
 Microswitch rating.....Belastung der Mikroschalter1(1)A, 250 VAC
 Actuator protection class.....AntreibsschutzartIP 54
 Terminals.....Anschlussklemmen0,5 ... 1 mm²
 Ambient temperature.....Umgebungstemperatur0...50 °C
 Humidity.....FeuchtRH0% - 80% NON CONDESED
 Fluid temperature.....Temperatur des Fluids.....5...110°C max
 Max. operating torque.....Max Ausgangsmoment25Nm

CODE	TYPE	DN	VOLTAGE	TIME
11225	EMV 110 820/410-5	32- 1 1/4"	230VAC, 50Hz	105s / 90°
11226	EMV 110 820/410-6	40 - 1 1/2"	230VAC, 50Hz	105s / 90°
11227	EMV 110 820/410-7	50 - 2"	230VAC, 50Hz	105s / 90°
*11290	EMV 110 820/413-5	32- 1 1/4"	24VAC, 50Hz	105s / 90°
*11291	EMV 110 820/413-6	40 - 1 1/2"	24VAC, 50Hz	105s / 90°
*11292	EMV 110 820/413-7	50 - 2"	24VAC, 50Hz	105s / 90°

with a relay / mit Relais

CODE	TYPE	DN	VOLTAGE	TIME
*11228	EMV 110 820/310-5	32- 1 1/4"	230VAC, 50Hz	105s / 90°
*11229	EMV 110 820/310-6	40 - 1 1/2"	230VAC, 50Hz	105s / 90°
*11230	EMV 110 820/310-7	50 - 2"	230VAC, 50Hz	105s / 90°
*11293	EMV 110 820/313-5	32- 1 1/4"	24VAC, 50Hz	105s / 90°
*11294	EMV 110 820/313-6	40 - 1 1/2"	24VAC, 50Hz	105s / 90°
*11295	EMV 110 820/313-7	50 - 2"	24VAC, 50Hz	105s / 90°

* by special request

Flow/pressure drop characteristic / Volumen Durchfluss und Druckabfall

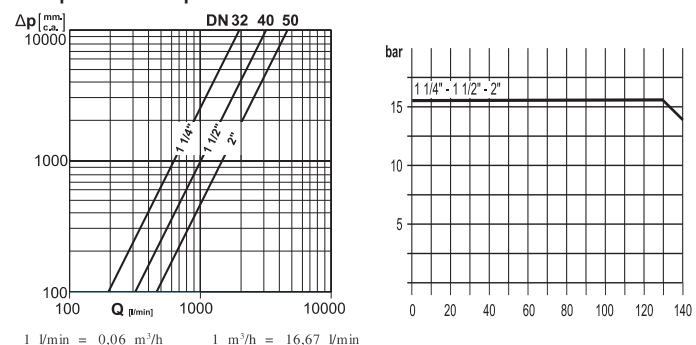

INDEXING BRACKET
EINSTELLBARER TRÄGER

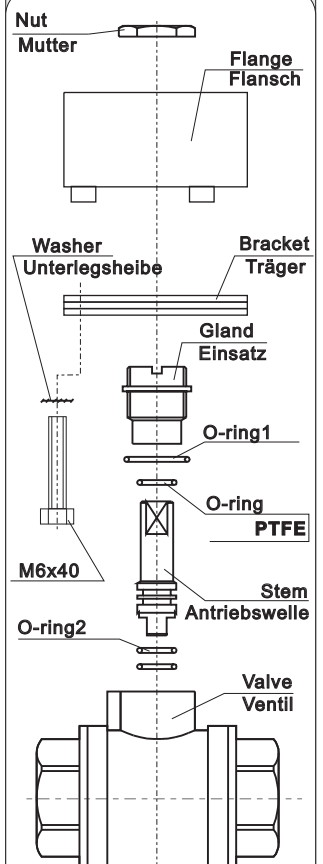

O-rings / O-Dichtungen	
5/4"	6/4" & 2"
15.6x1.78	19x2
9.25x1.78	13.5x2
Material : VITON (FPM)	

HYDRAULIC INSTALLATION: recommended instalation of the electric actuated ball valve
SCHEMA DER MASCHINENINSTALLATION: Empfohlener einbau des kugelventils mit elektromotorantrieb

flow direction
 Durchflußrichtung

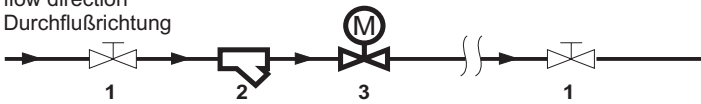

- 1 manual stop valve / manuelles Absperrventil Kugelventil
- 2 strainer with the mesh width 0,65 mm / Reinigungsfilter Y (für detaillierte Informationen bitte rufen Sie uns an lieferbar in Abmessungen von 1/2" bis 2"
- 3 motor actuated ball valve series EMV 110... / Elektromotorantrieb mit Kugelventil EMV 110...

IMPORTANT !

To extend the long term performance of the motorised ball valve it is recomended that a strainer is situated prior to the valve. By installation must be observed to according to relavant local standards.

WICHTIG!

Um die Lebensdauer des Ventil zu verlängern und Vernichtung der Dichtungen durch mechanische Teile in der Installation zu verhindern wird der Einbau eines Reinigungsfilters empfohlen. Die einschlägigen VDE+TÜV - Verschriftensindzubeschten.

MANUAL OPERATION / HANDSTEUERUNG



With a key 13 move slightly the valve in clockwise or contra clockwise direction in order to release the gears
 Schlüssel Nr. 13 auf Achse stecken



Press and rotate the button
 Knopf drücken

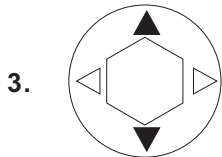

Rotate the valve with the key in desired position :
 - red : OPEN
 - blue : CLOSE
 Schlüssel in gewünschte Richtung drehen
 - rot = AUF
 - blau = ZU



Depress and rotate the button back to the original position
 Knopf loslassen

IMPORTANT / WICHTIG

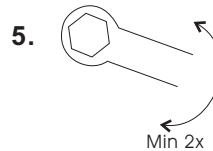

AFTER LONG STANDSTILL PERIOD
 Manually rotate the valve with a key for at least two full rotations to release the valve and to clean away impurities from the ball

NACH LÄNGEREM STILLSTAND
 Das ventil manuell mindestens zweimal um den Vollöffnungswinkel drehen, um die Verschmutzung von Ventilkugel zu entfernen und den Antrieb zu entlasten.

ELECTRICAL SCHEME / ELEKTRISCHE STEUERSCHHEME

EMV 110..410 (230VAC)
 EMV 110..413 (24VAC)

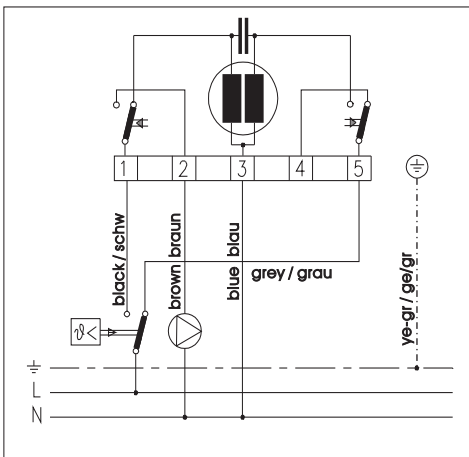

* with relay / mit relais
 EMV 110..310 (230VAC)
 EMV 110..313 (24VAC)

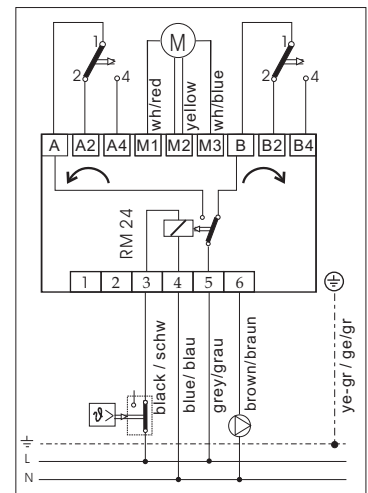

FIRŠT-ROTOTEHNIKA, s.p., Radegunda 54, SI-3330 Mozirje, SLOVENIJA
 tel: +386 3 898 35 00, fax:+386 3 898 35 35, e-mail:info@first.si, http://www.first.si