

ELECTRO-MOTOR ACTUATED ZONE BALL VALVES
SERIES EMV 110 602 and EMV 110 603
 with standard built in relay
 (EMV 110..4230-CR, EMV 110..4233-CR)

FIRST®

GENERAL

Electric motor driven ball valves, EMV 110 602 and 603 series, are used as locking elements for heating systems (solar, remote, house-heating), for hot blast heating, cooling systems, swimming pools, petrochemical industry, alternative heating sources and agricultural purposes.

With pride and joy we present to you our new generation of electric motor driven ball valves. They are constructed in compliance with most European standards and currently valid safety regulations. They are made of environmentally material.

Follow the instructions for use carefully and our many years experience in the production of electric motor drives will be a guarantee for a long life and reliable operation of the ball valve.



Series 602



Series 603

Advantages

- * Compact version enables quick installation and electrical connection without opening drive.
- * Clutch assembly enables manual opening / closing and unlocking of the valve if it locks during longer stand-stills.
- * All models have built-in relay module which enables two wire control SPST.
- * Simple disassembly of the drive with two screws only.
- * Electric signal - L (live) when the valve is open and can control the pump.
- * Main flow indicator on the support of the valve: RED-OPEN.
- * Additional flow indicator on the cover of the actuator
- * Moderate velocity of ball rotation prevents hydraulic shocks in installation.
- * Disassembly of installation is not required for the replacement of neck seals.
- * Due to self cleaning effect the valve need not be disassembled (if solid particles enter the valve), because motor turn ball to opposite direction.

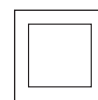
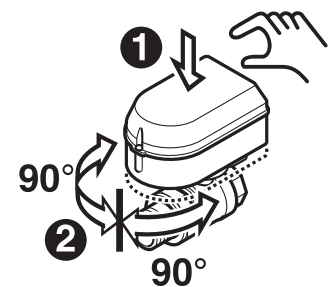

FIRST®



SI - 3330 Mozirje, Radegunda 54,
<http://www.first.si>
 e-mail: info@first.si



+386 3 898 35 00



+386 3 898 35 35

SERIES 602

ELECTRO-MOTOR ACTUATED ZONE BALL VALVE Ends: female/female

Electro-motor actuator
EMV 110...4230-CR (230VAC)
EMV 110...4233-CR (24VAC)
Rotation time 30s/90°
Built in relay
Drive protection class IP 44
Electrical protection: class II

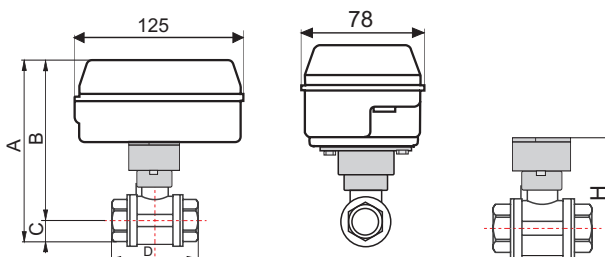

DESCRIPTION	DIMENSIONS	ORDER CODE	kg
Ball valve with electro-motor actuator EMV 110...4230-CR	DN15	10102	0.90
	DN 20	10103	0.83
	DN 25	10104	1.04
	DN 32	10105	1.24

G	DN	A	B	C	D	H	PN	KV	USA C V
1/2"	15	139	121.5	17.5	63	79	16	17	22
3/4"	20	144	124.5	19.5	57	85	16	41	50
1"	25	153	129.5	23.5	68	93	16	68	84
1 1/4"	32	163	134.5	28.5	81	103	16	123	153

SERIES 603

ELECTRO-MOTOR ACTUATED ZONE BALL VALVE Ends: male/ female hose union

Electro-motor actuator
EMV 110...4230-CR (230VAC)
EMV 110...4233-CR (24VAC)
Rotation time 30s/90°
Built in relay
Drive protection class IP 44
Electrical protection: class II

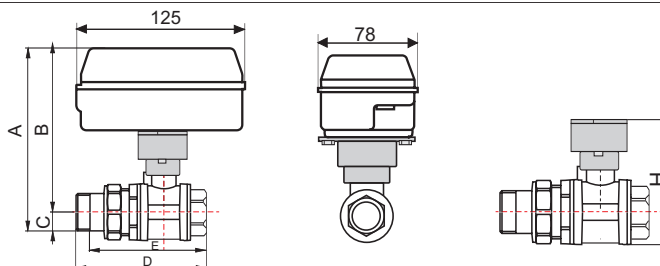

DESCRIPTION	DIMENSIONS	ORDER CODE	kg
Ball valve with electro-motor actuator EMV 110...4230-CR	DN 15	10112	0.93
	DN 20	10113	0.88
	DN 25	10114	1.10
	DN 32	10115	1.42

G	DN	A	B	C	D	E	H	PN	KV	USA C V
1/2"	15	139	121.5	17.5	99	86	79	16	17	22
3/4"	20	144	124.5	19.5	90.5	77.5	84	16	41	50
1"	25	153	129.5	23.5	104	90	93	16	68	84
1 1/4"	32	163	134.5	28.5	119.5	105.5	103	16	123	153

SPECIFICATIONS Electric actuator

Power supply: 230 V, 50/60 Hz (EMV 110..4230)
24V, 50Hz (EMV 110..4233)

Micro-switch rating: 1 (1) A, 250 V, 50 Hz

Power consumption: 7,5 VA by operation
3 VA by stand by

Electrical protection: class II according to EN-60335-1

Drive protection class: IP 44 according to IEC 529

Rotation time: 30s/90°

Ambient temperature: 0°C to max. 55°C

Humidity: RH0% - 80% NON CONDESED

Operating temperature: 5°C do 110°C

Max. operating pressure: PN 16

Max. operating torque: 8 Nm

connection cord: 4 x 0.5 mm², length 2m

Note:

The motorized ball valve is designed for operation by SPST (—●—/—).

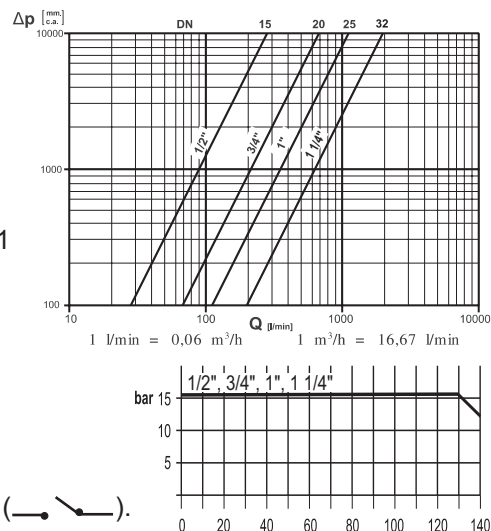

WIRING DIAGRAM:

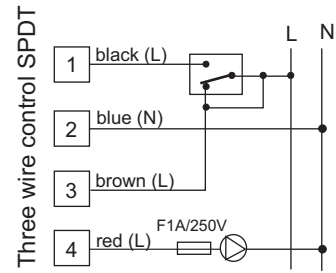
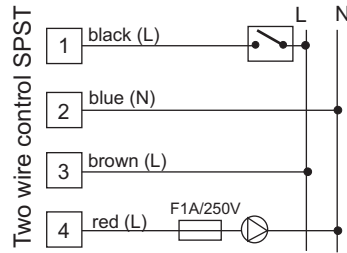
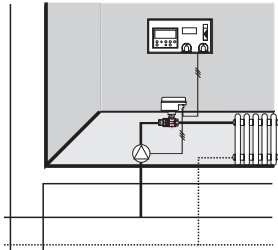

Circulation pump can be controlled at OPEN valve position by RED wire. Signal on the red wire is live (L) and can be used for inductive load up to one (1) A, 250VAC. For load which consumption is more than 1 A must be used external relay.

! IMPORTANT !

The electrical line supplying the actuator, the time counter and room thermostat must start from the thermal plant, so as to avoid tampering by user. Before any repair of the valve or the actuator disconnect the supply voltage.

Hydraulic installation - recommended installation

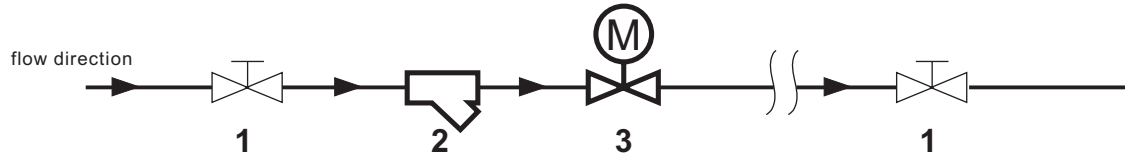

- 1 - manual stop valve
- 2 - strainer with the mesh width 0,65 mm
- 3 - motor actuated ball valve series EMV 110...4230-CR

IMPORTANT !

To extend the long term performance of the motorized ball valve it is recommended that a strainer is situated prior to the valve. By installation must be observed to according to relevant standards.

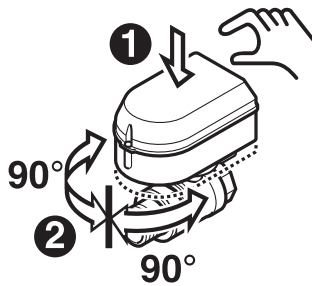

MANUAL CONTROL

Press the actuator towards the valve and turn it to left or right direction for angle 90°. Check also the position on indicator.

BALL VALVE'S STEM POSITION

By valve which is built in installation, OPEN/CLOSE condition is recognized from stem position.

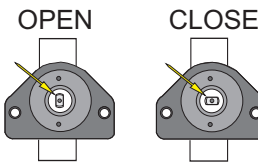

Ball position in the valve

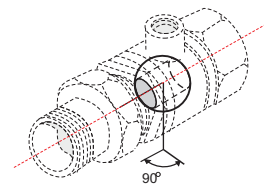

MAIN FLOW INDICATOR ON THE SUPPORT OF THE VALVE

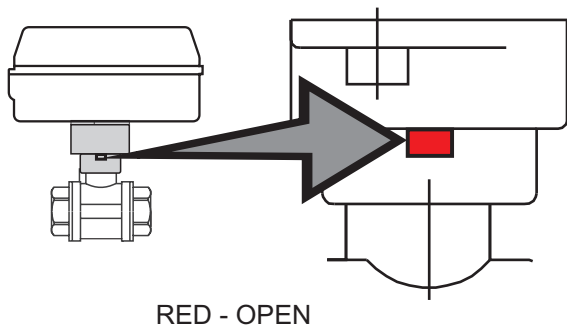

ADDITIONAL FLOW INDICATOR ON THE COVER OF THE ACTUATOR

... in case when the indicator on the support is not visible

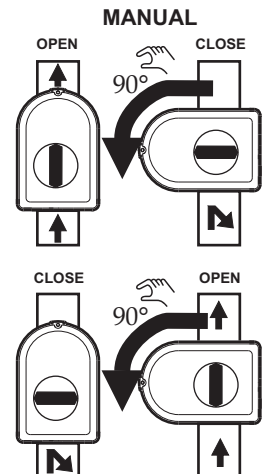
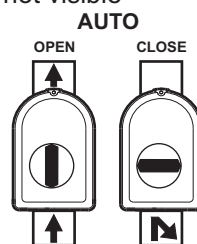

Assembly of the electric actuator on the ball valve

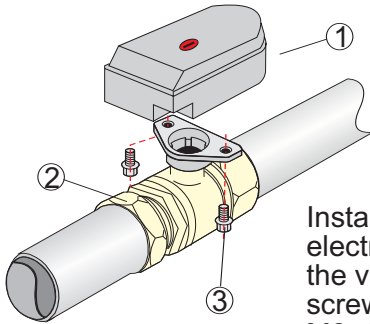

Install or remove the electric actuator ① on the valve ② by screwing two screws ③ M6x15

WARNING: the actuator must be in Parallel with the valve and pipes

RECOMMENDED INSTALLATION

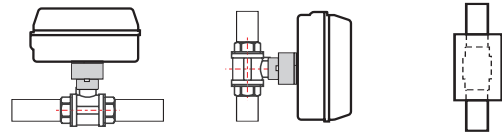

! FORBIDDEN !

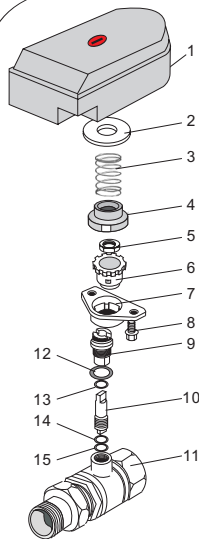

Assembly of the EMV 110...4230-CR

The electrical actuator is connected to the ball valve by hexagonal locking nut (5) which prevent the unscrewing the gland screw (2). On the valve is clutch assembly which offer manual operation like with the handle. Maintenance of the valve to replace the O-rings in the stem or replace the stem is easy and should be carried out as follows:

A- To separate valve and the actuator unscrew two hexagonal nuts (8) dimension M6x 15 with fork tool nr.10
B- Slightly turn in direction a plastic flange (2) cover as shown arrow on it.

WARNING! BY OPENING PLASTIC FLANGE SPRING CAN JUMP OUT AND DAMAGE THE EYES OR THIRD PERSON!

C- Pull the spring (3) and the red plastic indicator (4)
D- Unscrew hexagonal nut S19 (5) and separate the clutch assembly signed as (6) and (7) from the valve (11)

E- Unscrew gland screw (9) and pull it from the valve body

F- separate stem (10) and gland screw (9) by pull the stem from gland screw

G- Check the O-rings signed as 12, 14 and 15 and PTFE seal 13. If they are damaged, replace them

H- For assembling the and actuator repeat the operations in reverse order

O-rings

- (12) 14x1.78 EPDM
- (13) 12x 10x1 PTFE Unterlegscheibe
- (14) 8.73x 1.78 EPDM
- (15) 8.73x1.78 Viton

Advantages: O-rings in stem ensures maximum functionality, safety and tightness

WARNING: BEFORE DISASSEMBLY THE VALVE CHECK IF IN THE INSTALLATION IS NO PRESSURE OR HOT MEDIA. THIS CAN CAUSE INSTALLERSERIOUS DAMAGES ON EYES AND SKIN!

Examples for use:

Building with single-pipe hot water heating system

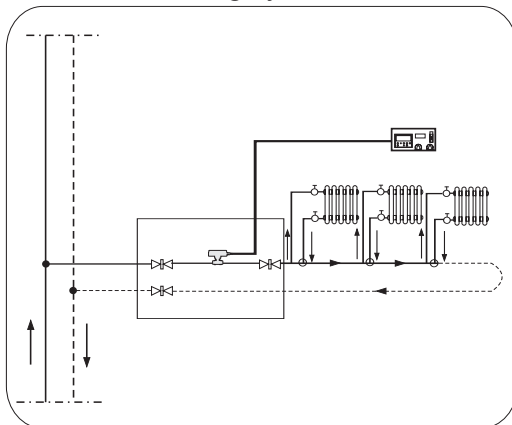

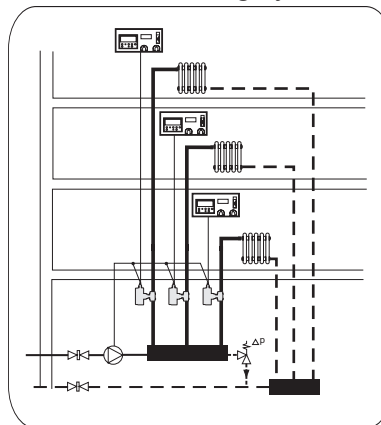

Heating control with one room thermostat and one electric actuated ball valve

Building with two pipe hot water heating system



Heating control of each flat separated with one room thermostat and one electric actuated ball valve

 ball valve with electro-motor actuator EMV 110..4230-CR

 room thermostat ELTHERM AT8 ELTHERM ST8